

User Manual Easy UPS On-Line SRVS Series 1000VA, 2000VA, 3000VA

Important Safety Information

Read the instructions carefully and look at the equipment to become familiar with the device before trying to install, operate, service or maintain it. The following special messages may appear throughout this document or on the equipment to warn of potential hazards or to call attention to information that clarifies or simplifies a procedure.



The addition of this symbol to a Danger or Warning product safety label indicates that an electrical hazard exists that will result in personal injury if the instructions are not followed.



This is the safety alert symbol. It is used to alert you to potential personal injury hazards. Obey all safety messages that follow this symbol to avoid possible injury or death.

DANGER

DANGER indicates a hazardous situation which, if not avoided, will result in death or serious injury.

WARNING

WARNING indicates a hazardous situation which, if not avoided, could result in death or serious injury.

CAUTION

CAUTION indicates a hazardous situation which, if not avoided, could result in minor or moderate injury.

NOTICE

NOTICE is used to address practices not related to physical injury.

Safety and General Information

SAVE THESE INSTRUCTIONS

This manual contains important instructions that should be followed during installation and maintenance of the UPS and batteries.

Inspect the package contents upon receipt. Notify the carrier and dealer if there is any damages.

- This UPS is for indoor use only.
- Do not operate this UPS in direct sunlight, in contact with fluids, or where there is excessive dust or high humidity.
- Do not operate the UPS near open windows or doors.
- Be sure the air vents on the UPS are not blocked. Allow adequate space for proper ventilation.

Note: Allow a minimum of 20 cm clearance on all four sides of the UPS.

- Environmental factors impact battery life. Elevated ambient temperatures, poor quality utility power, and frequent discharges will shorten battery life. Follow the battery manufacturer recommendations.
- Connect the UPS power cable directly to a wall outlet. Do not use surge protectors or extension cords.

Electrical Safety

- When grounding cannot be verified, disconnect the equipment from the utility power outlet before installing or connecting to other equipment. Reconnect the power cord only after all connections are made.
- Connection to the branch circuit (mains) must be performed by a qualified electrician.
- The protective earth conductor for the UPS carries the leakage current from the load devices (computer equipment). An insulated ground conductor is to be installed as part of the branch circuit that supplies the UPS. The conductor must have the same size and insulation material as the grounded and ungrounded branch circuit supply conductors. The conductor will be green and with or without a yellow stripe.
- The grounding conductor is to be grounded to earth at the service equipment, or if supplied by a separately derived system, at the supply transformer or motor generator set.

Battery Safety

⚠ CAUTION

HYDROGEN SULPHIDE GAS AND EXCESSIVE SMOKE

- Battery must be replaced when they reach end of service life.
- Batteries must be replaced when the unit indicates battery replacement is necessary.
- When replacing batteries, replace with the same number and type of batteries originally installed in the unit.

Failure to follow these instructions can result in minor or moderate injury and equipment damage.

- Do not dispose of batteries in a fire. The batteries may explode.
- Do not open or mutilate batteries. Released electrolyte is harmful to the skin and eyes, and may be toxic.
- Servicing of batteries should be performed or supervised by personnel knowledgeable about batteries and required precautions.
- Schneider Electric uses Maintenance-Free sealed Lead Acid batteries. Under normal use and handling, there is no contact with the internal components of the batteries. Over charging, over heating or other misuse of batteries can result in a discharge of battery electrolyte. Released electrolyte is toxic and may be harmful to the skin and eyes.
- **CAUTION:** Before replacing batteries, remove conductive jewelry such as chains, wrist watches, and rings. High energy through conductive materials could cause severe burns.

Radio Frequency Warning

This is a category C2 UPS product. In a residential environment, this product may cause radio interference, in which case the user may be required to take additional measures.

Product Description

The Schneider Electric Easy UPS is a high performance, uninterruptible power supply (UPS). The UPS provides protection for electronic equipment from utility power blackouts, brownouts, sags, and surges and small utility fluctuations and large disturbances. The UPS also provides battery backup power for connected equipment until utility power returns to normal levels or the batteries are fully discharged.

This user manual is available on the enclosed Documentation CD and on the Schneider Electric website, www.apc.com.

Package Contents

Read the Safety Guide before installing the UPS.

The packaging is recyclable; save it for reuse or dispose of it properly.

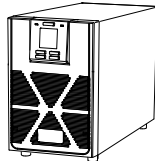

(1)
UPS



(1)
User manual

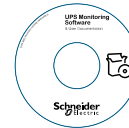

(1)
Software, User
documentation CD



(1)
USB cable



(1*)
Utility power cable



(1**)
Output cable

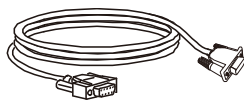

(1)
RS-232 cable

*: based on the local input plug to select.

** : only for the models with IEC outlet (10A).

NOTE: The model and serial numbers are located on a small, top cover label.

Optional Accessories

For optional accessories, refer to the Schneider Electric Website at www.apc.com.

Specifications

Environment Specifications

NOTICE



RISK OF EQUIPMENT DAMAGE

- UPS must be used indoors only.
- The installation location should be sturdy to withstand the weight of the UPS.
- Do not operate UPS where there is excessive dust or where the temperature or humidity are outside specified limits.

Failure to follow these instructions can result in equipment damage.

Temperature	Operating	0° to 40°C at rated load. 40° to 50°C linearly derated to 80% of maximum load capacity.	<p>This unit is intended for indoor use only. Select a location sturdy enough to handle the weight.</p> <p>Do not operate UPS where there is excessive dust or where the temperature or humidity are outside specified limits.</p> <p>Note: Charge the battery modules every six months during storage.</p>
	Storage	-20° to 50°C	
Elevation	Operating	0 - 1,000 m: normal operation 1,000 - 3,000 m: The load reduces @ 1% at an increased height of every 100 m > 3,000 m: UPS will not work	
	Storage	0 - 15,000 m	
Humidity		0 to 95% relative humidity, non-condensing	

Physical Specifications

UPS model	SRVS 1000VA	SRVS 2000VA	SRVS 3000VA
Dimensions with package Width x Height x Depth	235 mm (9.25in) x 330 mm (12.99in) x 365 mm (14.37 in)	235 mm (9.25in) x 355 mm (13.98in) x 525 mm (20.67 in)	325 mm (12.8 in) x 465 mm (18.31 in) x 565 mm (22.24 in)
Dimensions without package Width x Height x Depth	145 mm (5.7 in) x 223 mm (8.78 in) x 288 mm (11.34 in)	145 mm (5.7 in) x 238mm (9.37in) x 400 mm (15.75 in)	190 mm (7.5 in) x 336 mm (13.2in) x 425 mm (16.7 in)
Weight with package	10.6kg	18.1kg	29kg
Weight without package	9.3kg	16.8kg	26.8kg
Lifting guidelines	< 18 kg (< 40 lb) 	18 - 32 kg (40 - 70lb) 	18 - 32 kg (40 - 70lb) 

Input/Output Specifications

UPS Model	SRVS 1000VA	SRVS 2000VA	SRVS 3000VA	
Input	Voltage			
	230 Vac Nominal			
	Frequency			
	40 – 70 Hz			
	Input Voltage Range (100% load)			
	160 Vac – 280 Vac			
Input Voltage Range (50% load)				
110 Vac – 285Vac				
Input Power Factor (100% resistive load)				
≥ 0.99 in Green mode ≥ 0.93 in Normal mode				
Input Protection				
Input circuit breaker				
Output	UPS Capacity	1000 VA / 800 W	2000 VA / 1600 W	3000 VA / 2400 W
	Nominal Output Voltage	230 Vac		
	Other Programmable Voltage	220 Vac, 240 Vac		
	Efficiency at rated load	88% max.		
	Output Voltage Regulation	± 1% static		
	Output Voltage Distortion	<ul style="list-style-type: none"> • 3% max. for full linear load, • 6% max. for full RCD load (100% VA, 0.8 PF) • 15% for the last 60 seconds of the backup time (with full load only for the internal battery) 		
	Frequency – On Battery	50 Hz ± 0.5% or 60 Hz ± 0.5%		
	Frequency – AC Mode	50 Hz ± 3 Hz or 60 Hz ± 3 Hz		
	Crest Factor	3:1		
	Waveform	Sinewave		
	Output Connection	Please refer to rear panel features		
Bypass	Internal bypass			

Battery

UPS Model	SRVS 1000VA	SRVS 2000VA	SRVS 3000VA
Configuration	Internal battery		
Type	Sealed maintenance free (SMF) 12 V, 9 Ah		
Battery Bank Voltage	24 V	48 V	72 V

Front Panel Display

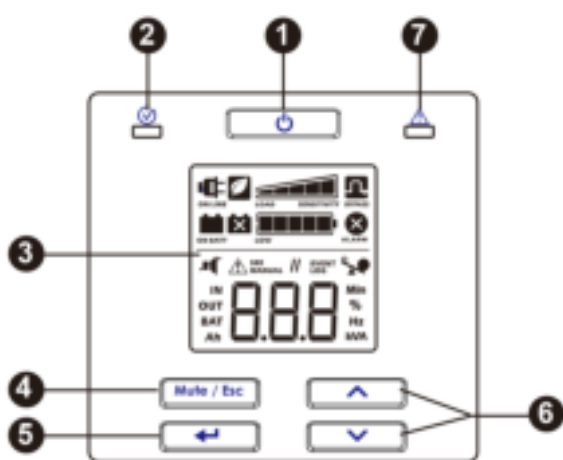

- 1 UPS Power On/Off button
- 2 Status LED
- 3 LCD Display
- 4 Mute/Esc button
- 5 Enter button
- 6 Up / Down button
- 7 Alarm LED

Rear Panel Features

SRVS 1000VA

Model	Output type and quantity
SRVS1KI	 x 3

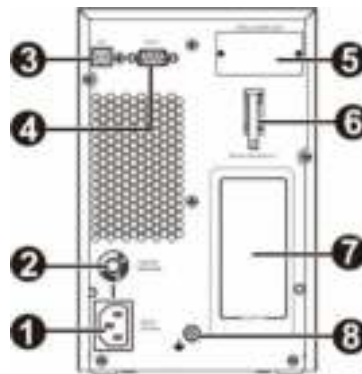

- 1** AC input
- 2** Input circuit breaker
- 3** USB port
- 4** RS-232
- 5** Intelligent card slot
- 6** Battery disconnecter
- 7** Outlet Group (refer to outlet type and quantity in the left side)
- 8** Ground Screw

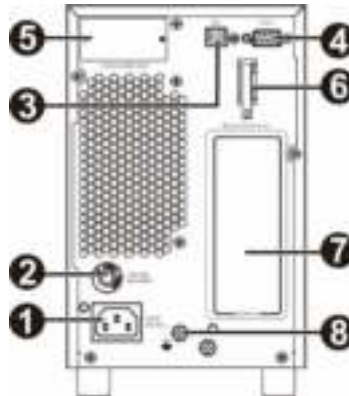

SRVS 2000VA

Model	Output type and quantity
SRVS2KI	 x4



- 1** AC input
- 2** Input circuit breaker
- 3** USB port
- 4** RS-232
- 5** Intelligent card slot
- 6** Battery disconnecter
- 7** Outlet Group (refer to outlet type and quantity in the left side)
- 8** Ground Screw

SRVS 3000VA

Model	Output type and quantity
SRVS3KI	 x6
	 x1

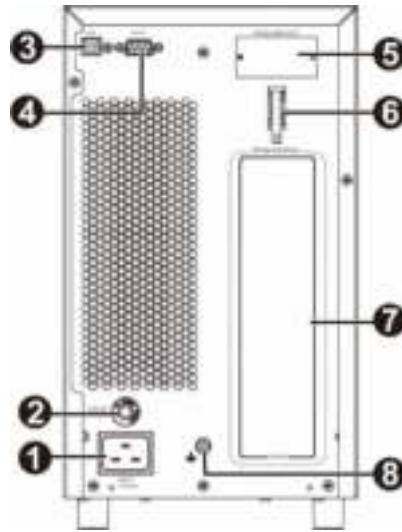

- 1** AC input
- 2** Input circuit breaker
- 3** USB port
- 4** RS-232
- 5** Intelligent card slot
- 6** Battery disconnecter
- 7** Outlet Group (refer to outlet type and quantity in the left side)
- 8** Ground Screw

Basic Connectors

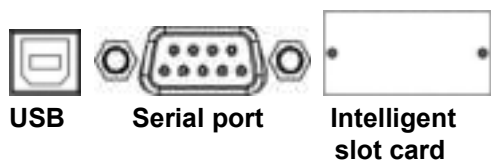

USB

Serial port

Intelligent slot card

Power management software and interface kits can be used with the UPS.

Use only interface kits supplied or approved by Schneider Electric.

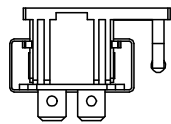

Battery disconnecter

This UPS is equipped internal battery. For batteries without connecting when the UPS is shipped out from factory. Before turn on the UPS. Please connect the battery by pulling the handle up, and then pushing it into the unit.

Start Up Settings

Connect the battery

Connect the battery by pulling the battery handle up, and then pushing it into the unit.

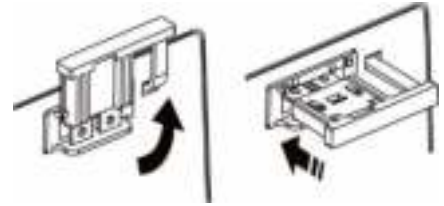

Connect power and equipment to the UPS

⚠ CAUTION

HAZARD OF ELECTRIC SHOCK

- All electrical work must be performed by a qualified electrician.
- Turn off all power to this equipment before working on the equipment. Practice lockout/tagout procedures.
- Do not wear jewelry when working with electrical equipment.

Failure to follow these instructions can result in minor or moderate injury.

1. Connect equipment to the UPS. Avoid using extension cords.
2. Connect input utility power to the UPS.
3. Switch on the input utility power. Then, the UPS display panel will illuminate when utility power is available.



Start the UPS

Press the  button located on the front panel of the UPS.

- The battery charges to 90% capacity during the first five hours of normal operation.
- **Do not** expect full battery run capability during this initial charge period.



Cold start the UPS

Use cold start feature to supply power to connected equipment from the UPS batteries.

Press the  button. Then, the display panel will illuminate. Press the  button again to supply battery power to the connected equipment.

Connect and install management software

Easy UPS SRVS is provided with SchneiderUPS management software for unattended operating system shutdown, UPS monitoring, UPS control and energy reporting. The following diagram is a representation of a typical server installation.

1. Connect the USB cable from the rear of the UPS  to the protected device such as a server.
2. For a server or other device with an operating system, load the SchneiderUPS CD and follow the on-screen set-up instructions.
3. A built-in serial port  is also available for additional communication options with serial cable.
4. Even more communication options are available via the built-in intelligent card slot. Refer to www.apc.com for more information.

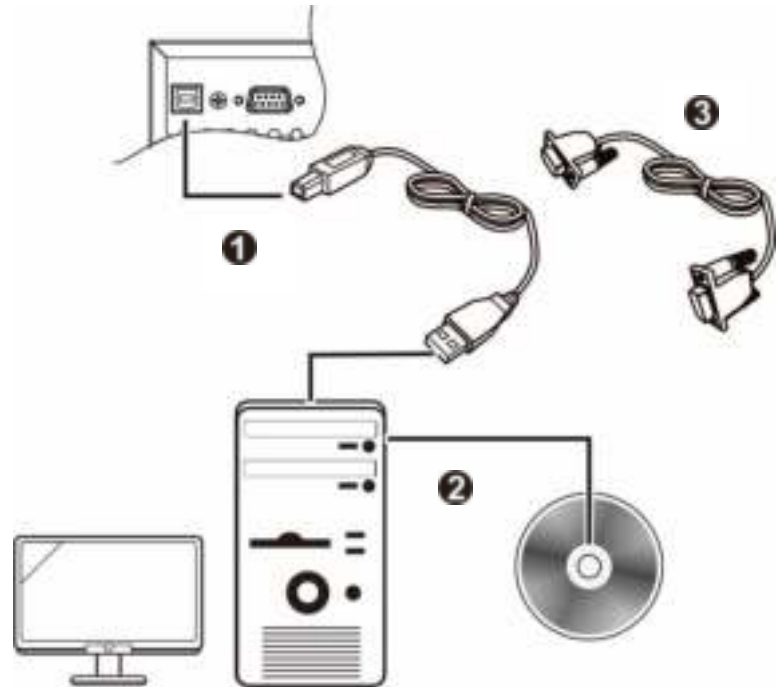







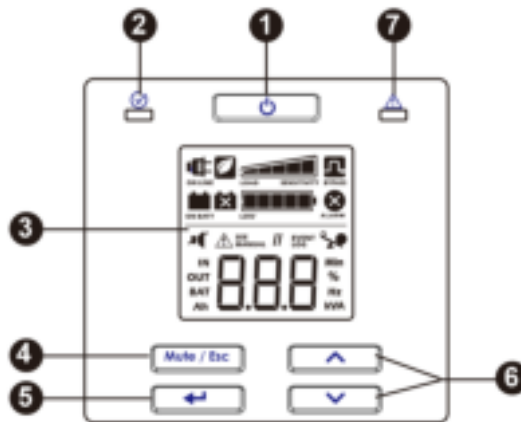

Operation









Using The Display

These Easy UPS models are equipped with an intuitive and configurable LCD display. This display complements the software interface as they convey similar information and either may be used to configure the UPS settings. The display consists of the following keys and indicators:



1	UPS Power On/Off button 	<ul style="list-style-type: none"> ● Press this button to turn on the UPS. ● Press and hold this button until a beep is heard to turn off the UPS. ● Press this button to reset alarms.
2	Status LED 	<p>The Status LED illuminates green when the power is on. This LED indicates two different states of output power:</p> <ul style="list-style-type: none"> ● Output off: LED blinks. Press Power On/Off button to turn the output power on. ● Output on: LED illuminates green continuously.
3	LCD Display	<p>The display interface options are visible on this LCD screen. Press the  or  button to activate LCD, if the display is not illuminated.</p>
4	Mute/Esc button 	<ul style="list-style-type: none"> ● To acknowledge audible alarms and suppress them temporarily. ● To exit a sub menu and return to the main menu.
5	Enter button 	<p>Press this button to enter the menu or to select a menu item/ value during navigation.</p>
6	Up / Down button  	<p>Press these two buttons to scroll through the main menu options and display screens.</p>
7	Alarm LED 	<p>This Alarm LED illuminates red when the UPS detects an error and blinks red for UPS notifications. See “ Alarms and Notifications” on page 11 in this manual.</p>

LCD Display Icons

 ON LINE	<p>On Line: The UPS is drawing utility power and performing double conversion to supply power to the connected equipment.</p>
 ON BATT	<p>On Battery: The UPS is supplying battery backup power to the connected equipment.</p>
	<p>Replace Battery: The battery is not connected securely or the battery is nearing the end of its service life and should be replaced.</p>
 BYPASS	<p>Bypass: The UPS is in bypass mode, sending utility power directly to connected equipment. Bypass mode operation is the result of an internal UPS event or an overload condition. Battery operation is not available while the UPS is in bypass mode. See “Alarms and Notifications” on page 11 in this manual. This icon in combination with Green Mode icon, indicates that the UPS is in green mode operation.</p>
 ALARM	<p>System Alarms: An internal fault is detected. See “Alarms and Notifications” on page 11 in this manual.</p>
	<p>Overload: The equipment connected to the UPS is drawing more power than rated.</p>
 LOW	<p>Battery Charge: The battery charge level is indicated by the number of bar sections illuminated. When all five blocks are illuminated, the battery is fully charged. Each bar represents approximately 20% of the battery charge capacity.</p>
 LOAD SENSITIVITY	<p>Load Level: The load percentage is indicated by the number of load bar sections illuminated. Each bar represents approximately 20% of the maximum load capacity.</p>
	<p>Mute: An illuminated line through the icon indicates that the audible alarm is disabled.</p>



Green Mode: An illuminated icon indicates that the unit is working in Green mode. The connected equipment is receiving the utility input directly as long as the input voltage and frequency are within the configured limits.



Alarm or notification: The UPS has detected an error or the UPS is in configuration mode. See “Alarms and Notifications” on page 11 in this manual.

EVENT LOG



Event: The icon is illuminated when the user is viewing the event log.

Alarms and System Errors

Status Indicators

Continuous beeps, every half second	Low Battery State - The battery is nearing its complete discharge state. The UPS is about to shut down.
4 beeps every 30 sec (first beep starts after 4 sec on battery)	Overload condition - The equipment connected to the UPS is drawing more power than rated.
Beeper continuously on	On Battery State - The UPS is supplying battery backup power to the connected equipment.
Short beep every 2.5 sec	Alarm State - UPS has detected an error. See “Alarms and Notifications” in this manual.
Continuous short beeps for every half second for 1 minute, repeats every 5 hours.	Battery disconnected.
Two short beeps every 5 sec	Bad battery (replace)
	Event Bypass State - UPS has detected an error. Connected equipment receives utility input power through the bypass relay.

Alarms

Display code	Description	Solution
SC	UPS has experienced a short circuit at the output. Unit will try to auto-recover from this condition.	Check if there is any short circuit at the UPS output. Remove the short circuit wait the unit auto-recover or Press  button to start the UPS. Note: The power supplied to the connected equipment is dropped when the UPS is in this condition.
OL	UPS is experiencing an overload condition.	Disconnect nonessential equipment from the UPS to eliminate the overload condition.
dCH	The UPS has detected a DC voltage error. Unit will try to auto-recover from this condition.	If the UPS does not recover automatically, contact Schneider Electric.
Hot	Temperature of the unit is rising above the set limits.	Disconnect nonessential equipment from the UPS to reduce the UPS load. Ensure that ambient temperature is within limits. Ensure that adequate clearance is maintained.
CH9	UPS has detected a charger error.	Verify if there is any short circuit at the UPS battery terminal. Press  button to start the UPS.

Contact Schneider Electric for all other alarm codes.

Notifications

Display code	Description	Solution
bdc	Battery is not connected.	Connect battery to the UPS. See “Start Up” on page 8 in this manual.

UPS Display Parameters

Operational data displayed in the display panel is given in the table.















Navigate using the  or  button.

Parameter	Units	Indicator Icons
Output voltage	Vac	OUT, V
Output frequency	Hz	OUT, Hz
Input voltage	Vac	IN, V
Input frequency	Hz	IN, Hz
Battery voltage	V DC	BAT, V
Ambient temperature	° C	NUMBER, C
State of battery charge	%	BAT, %
Load level in percentage (Maximum of Watts or VA)	%	OUT, %
Load level in kVA	kVA	OUT, kVA
Total Ah capacity of connected battery	Ah	BAT, Ah
Remaining On Battery runtime	Minutes	BAT, Min

Configuration

Configure UPS Parameters

Follow the steps to configure parameters in the UPS:



1. Press the  button.
2. Press the  or  button to navigate to “Set”.
3. Press the  button.
4. Navigate through the parameters using the  or  button.
5. Press the  button to edit a parameter. Icons start flashing to indicate the editing.
6. Press the  or  button to navigate between the options available for the selected parameter.
7. Press the  button to select the option or  button to abort the editing of current parameter. Flashing of icons stops after this.
8. Press the  or  button to navigate between parameters.
9. Press the  button to exit menu navigation.









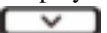

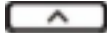

UPS Settings

Configure UPS settings using the display interface. See “Configure UPS parameters” section to edit the parameters.

Function	Factory Default	User Selectable Options	Description
Output voltage	230 Vac	220, 230, 240 Vac	Allows the user to select output voltage while the UPS is operating online.
Audible alarm	Enable	Enable, disable	UPS will mute audible alarms when setting to disable or when the display panel MUTE button is pressed.
Green mode/ high efficiency mode	Disabled	Enable/Disable	When this mode is enabled, connected equipment receives utility input power through the bypass relay as long as input voltage is within the range of $\pm 5\%$ of configured output voltage and ± 3 Hz of configured output frequency. Inverter is turned off during this mode. If utility power input goes out of range, inverter is turned on. The load is transferred to online mode or battery mode. The power to the connected equipment may be interrupted up to 10 milliseconds.
Minimum battery capacity to restart setting	0%	0%, 15%,50%,90%,	UPS output will not be turned on until the battery is charged to a level such that it can provide the runtime configured by this setting. If configured to 0%, UPS output is turned on immediately after utility power returns.
Low battery state indication setting	2 min	2 min, 5 min, 7min, 10min,	The UPS will emit audible alarm when the actual run time reaches the limit set by the end user. The audible alarm will emit only when the UPS is working in battery mode.

Advance Display Navigation

There are five options in main menu and two sub-menu options in UPS display. Press the  button from the Home Screen to access these menu options. Use the  or  button to navigate between the menu options.

Menu Option	Description								
SET	<p>Configure the UPS Use this menu option to configure the UPS parameters. Press the  button to see the configuration options. See “Configure UPS parameters” on page 13 for details. Press the  button to return to the Home Screen.</p>								
LOG	<p>Show Event Log Use this menu option to see the UPS event log. The UPS records the last 10 events and displays the codes in this log. Press the  button to see the log. Use the  or  button to see the logged events. The  button navigates towards old events and the  button navigates to new events. Every log entry has a numeric and textual event code. At the end of the log, the word “End” will be displayed. Press the  button to return to the Home Screen.</p>								
UPS	<p>Show UPS information Use this menu option to see the UPS information. Press the  button to see the rating of the UPS. Press the  button to see the UPS firmware version. Press the  button to return to the Home Screen.</p>								
bYP	<p>User Command to bypass Use this menu option to switch the UPS to bypass mode or bring the UPS to online mode from bypass mode. Press  button: <table style="margin-left: 20px;"> <tr> <td style="padding-right: 20px;">Put</td> <td>Put: Use to switch the UPS to bypass mode of operation.</td> </tr> <tr> <td style="padding-right: 20px;">Out</td> <td>Note: Power to the connected equipment will drop, if the mains voltage is not within the threshold limits.</td> </tr> <tr> <td></td> <td>Out: Bring the UPS out of bypass and restore clean power to the connected equipment.</td> </tr> </table> </p>	Put	Put: Use to switch the UPS to bypass mode of operation.	Out	Note: Power to the connected equipment will drop, if the mains voltage is not within the threshold limits.		Out: Bring the UPS out of bypass and restore clean power to the connected equipment.		
Put	Put: Use to switch the UPS to bypass mode of operation.								
Out	Note: Power to the connected equipment will drop, if the mains voltage is not within the threshold limits.								
	Out: Bring the UPS out of bypass and restore clean power to the connected equipment.								
tSt	<p>Execute Battery Self-Test Use this menu option to conduct a self-test and determine the battery status. Press the  button to initiate the test. If the test command is accepted, the UPS will initiate a self-test and will start a count down on the display. Display messages are shown at the end of the test.</p> <table style="margin-left: 20px;"> <tr> <td style="padding-right: 20px;">rFd</td> <td>Test refused. The output is off or battery is not charged.</td> </tr> <tr> <td style="padding-right: 20px;">FI d</td> <td>Test not passed</td> </tr> <tr> <td style="padding-right: 20px;">PAS</td> <td>Test passed</td> </tr> <tr> <td style="padding-right: 20px;">Abt</td> <td>Test is aborted due to internal reasons</td> </tr> </table> <p>Press the  button to return to the Home Screen</p>	rFd	Test refused. The output is off or battery is not charged.	FI d	Test not passed	PAS	Test passed	Abt	Test is aborted due to internal reasons
rFd	Test refused. The output is off or battery is not charged.								
FI d	Test not passed								
PAS	Test passed								
Abt	Test is aborted due to internal reasons								

Troubleshooting

Use the table below to solve minor installation and operation problems. Refer to the Schneider Electric website, www.apc.com for assistance with complex UPS problems.

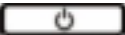
Problem and/or Possible Cause	Solution
UPS will not turn on when utility input is available or there is no power output	
The UPS is not turned on.	Press the  button to turn on the UPS.
The UPS is not connected to utility power supply.	Check that the power cable from the UPS to the utility power supply is securely connected at both ends. See “Start Up” on page 8 in this manual.
Input thermal circuit breaker on the UPS is tripped.	Press the input thermal circuit breaker reset button in the rear panel.
The UPS is operating on battery, while connected to the input utility power	
There is high, low, or distorted input voltage or frequency.	Connect the UPS to a different outlet on a different circuit. Test the utility input power to ensure the unit is receiving input power. If display is on, navigate and check the input voltage and frequency.
UPS, when connected to battery, is not supplying power to the connected equipment	
The UPS is not turned on.	If the UPS has shutdown (the display is not on), follow the procedure “Cold start the UPS” on page 8.
The battery is not connected.	Connect battery to the UPS. See “Start Up” on page 8 in this manual.
Low battery cut off. UPS may have discharged the battery due to utility power outage and turned the output off due to low battery condition.	Wait for the utility power to return and charge the battery. To turn on the output power after utility power returns, press  button.
UPS emits an audible beeping sound at long intervals	
The UPS is operating normally when running on battery.	UPS has detected an error. See “Alarms and Notifications” on page 11 in this manual.
Alarm LED is illuminated. The UPS displays an alarm message and emits a constant beeping sound	
The UPS has detected an error.	See “Alarms and Notifications” on page 11 in this manual.
No audible sounds from UPS even when the Alert LED is illuminated.	
Audible alarm is disabled.	Change the UPS configuration to enable audible alarms.
UPS is not providing expected backup time.	
The UPS battery is discharged due to a recent power outage.	The batteries require recharging after extended outages. Batteries can wear faster when put into service without proper recharging or when operated at elevated temperatures.
The battery is near the end of its service life.	If the battery is near the end of its service life, consider replacing the battery, even if the replace battery indicator is not illuminated. See “Start Up” on page 8 in this manual.

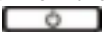
Problem and/or Possible Cause	Solution
UPS is not turning off	
POWER OFF button not pressed properly	Press and hold the  button until the beep is heard to power off the UPS.
Utility input power is available.	UPS logic power can not be turned off if utility input power is available. To turn off the UPS, turn off utility input power and press  button. Release when a beep is heard.
UPS is in Bypass mode and the LED is not illuminated red.	
UPS is in green mode.	Disable green mode if not desired.
UPS is configured to stay in the bypass mode.	Change the configuration to exit bypass mode.
UPS is in bypass mode even after over temperature alarm is cleared.	Reduce the connected load to <90% to bring the UPS to online mode.
The UPS has experienced an overload condition and transferred to bypass.	<p>Connected equipment exceeds the “maximum load” as defined in specifications on the Schneider Electric Website, www.apc.com.</p> <p>The alarms remain on until the overload condition is corrected. Disconnect nonessential equipment from the UPS to eliminate the overload condition.</p> <p>The UPS continues to supply power as long as it is in bypass mode and the circuit breaker does not trip. The UPS will not provide battery power in the event of a utility voltage interruption.</p>
UPS detected an error and transferred to bypass.	See “Alarms and Notifications” on page 11 in this manual.

Transport

1. Shut down and disconnect all connected equipment.
2. Disconnect the unit from mains power.
3. Disconnect all internal and external batteries (if applicable).
4. Follow the shipping instructions outlined in the *Service* section of this manual.

Service

If the unit requires service, do not return it to the dealer. Follow these steps:

1. Review the *Troubleshooting* section of the manual to eliminate common problems.
2. If the problem persists, contact Schneider Electric Customer Support through the Schneider Electric website, **www.apc.com**.
 - a. Note the model number and serial number and the date of purchase. The model and serial numbers are located on the rear panel of the unit and are available through the LCD display on select models.
 - b. Call Customer Support. A technician will attempt to solve the problem over the phone. If this is not possible, the technician will issue a Returned Material Authorization Number (RMA#).
 - c. If the unit is under warranty, the repairs are free.
 - d. Service procedures and returns may vary internationally. For country specific instructions refer to the Schneider Electric website, **www.apc.com**.
3. Pack the unit properly to avoid damage in transit. Never use foam beads for packaging. Damage sustained in transit is not covered under warranty.
Note: Before shipping, always disconnect battery modules in a UPS or external battery pack. The disconnected internal batteries may remain inside the UPS or external battery pack.
4. Write the RMA# provided by Customer Support on the outside of the package.
5. Return the unit by insured, prepaid carrier to the address provided by Customer Support.

Limited Factory Warranty

Schneider Electric IT Corporation (SEIT), warrants its products to be free from defects in materials and workmanship for a period of two (2) years from the date of purchase. The SEIT obligation under this warranty is limited to repairing or replacing, at its own sole option, any such defective products. Repair or replacement of a defective product or part thereof does not extend the original warranty period.

This warranty applies only to the original purchaser who must have properly registered the product within 10 days of purchase. Products may be registered online at warranty.apc.com.

SEIT shall not be liable under the warranty if its testing and examination disclose that the alleged defect in the product does not exist or was caused by end user or any third person misuse, negligence, improper installation, testing, operation or use of the product contrary to SEIT recommendations of specifications. Further, SEIT shall not be liable for defects resulting from: 1) unauthorized attempts to repair or modify the product, 2) incorrect or inadequate electrical voltage or connection, 3) inappropriate on site operation conditions, 4) Acts of God, 5) exposure to the elements, or 6) theft. In no event shall SEIT have any liability under this warranty for any product where the serial number has been altered, defaced, or removed.

EXCEPT AS SET FORTH ABOVE, THERE ARE NO WARRANTIES, EXPRESS OR IMPLIED, BY OPERATION OF LAW OR OTHERWISE, APPLICABLE TO PRODUCTS SOLD, SERVICED OR FURNISHED UNDER THIS AGREEMENT OR IN CONNECTION HEREWITH.

SEIT DISCLAIMS ALL IMPLIED WARRANTIES OF MERCHANTABILITY, SATISFACTION AND FITNESS FOR A PARTICULAR PURPOSE.

SEIT EXPRESS WARRANTIES WILL NOT BE ENLARGED, DIMINISHED, OR AFFECTED BY AND NO OBLIGATION OR LIABILITY WILL ARISE OUT OF, SEIT RENDERING OF TECHNICAL OR OTHER ADVICE OR SERVICE IN CONNECTION WITH THE PRODUCTS.

THE FOREGOING WARRANTIES AND REMEDIES ARE EXCLUSIVE AND IN LIEU OF ALL OTHER WARRANTIES AND REMEDIES. THE WARRANTIES SET FORTH ABOVE CONSTITUTE SEIT'S SOLE LIABILITY AND PURCHASER EXCLUSIVE REMEDY FOR ANY BREACH OF SUCH WARRANTIES. SEIT WARRANTIES EXTEND ONLY TO ORIGINAL PURCHASER AND ARE NOT EXTENDED TO ANY THIRDPARTIES.

IN NO EVENT SHALL SEIT, ITS OFFICERS, DIRECTORS, AFFILIATES OR EMPLOYEES BE LIABLE FOR ANY FORM OF INDIRECT, SPECIAL, CONSEQUENTIAL OR PUNITIVE DAMAGES, ARISING OUT OF THE USE, SERVICE OR INSTALLATION OF THE PRODUCTS, WHETHER SUCH DAMAGES ARISE IN CONTRACT OR TORT, IRRESPECTIVE OF FAULT, NEGLIGENCE OR STRICT LIABILITY OR WHETHER SEIT HAS BEEN ADVISED IN ADVANCE OF THE POSSIBILITY OF SUCH DAMAGES. SPECIFICALLY, SEIT IS NOT LIABLE FOR ANY COSTS, SUCH AS LOST PROFITS OR REVENUE, WHETHER DIRECT OR INDIRECT, LOSS OF EQUIPMENT, LOSS OF USE OF EQUIPMENT, LOSS OF SOFTWARE, LOSS OF DATA, COSTS OF SUBSTITUANTS, CLAIMS BY THIRD PARTIES, OR OTHERWISE.

NOTHING IN THIS LIMITED WARRANTY SHALL SEEK TO EXCLUDE OR LIMIT SEIT LIABILITY FOR DEATH OR PERSONAL INJURY RESULTING FROM ITS NEGLIGENCE OR ITS FRAUDULENT MISREPRESENTATION OF TO THE EXTENT THAT IT CANNOT BE EXCLUDED OR LIMITED BY APPLICABLE LAW.

To obtain service under warranty you must obtain a Returned Material Authorization (RMA) number from customer support. Customers with warranty claims issues may access the SEIT worldwide customer support network through the Schneider Electric website: www.apc.com. Select your country from the country selection drop down menu. Open the Support tab at the top of the web page to obtain information for customer support in your region. Products must be returned with transportation charges prepaid and must be accompanied by a brief description of the problem encountered and proof of date and place of purchase.

Schneider Electric IT Worldwide Customer Support

Customer support for this or any other Schneider Electric product is available at no charge in any of the following ways:

- Visit the Schneider Electric website to access documents in the Schneider Electric Knowledge Base and to submit customer support requests.
 - **www.apc.com** (Corporate Headquarters)
Connect to localized Schneider Electric websites for specific countries, each of which provides customer support information.
 - **www.apc.com/support/**
Global support searching Schneider Electric Knowledge Base and using e-support.
- Contact the Schneider Electric IT (SEIT) Customer Support Center by telephone or e-mail.
 - Local, country specific centers: go to **www.apc.com/support/contact** for contact information.

For information on how to obtain local customer support, contact the Schneider Electric representative or other distributor from whom you purchased your Schneider Electric product.

Manuel d'utilisation Easy UPS On-Line série SRVS 1000 VA, 2000 VA, 3000 VA

Instructions de sécurité importantes

Lisez attentivement les instructions et examinez le matériel pour vous familiariser avec l'appareil avant de l'installer, de l'utiliser, de le réviser ou de l'entretenir. Les messages suivants peuvent apparaître dans ce document ou sur le matériel pour vous avertir des dangers éventuels ou pour rappeler une information qui clarifie ou simplifie une procédure.



L'ajout de ce symbole à une étiquette de sécurité Danger ou Avertissement indique qu'un danger électrique existe et qu'il entraînera des blessures corporelles si les instructions ne sont pas suivies.



Ce symbole est le symbole d'avertissement de sécurité. Il est utilisé pour vous alerter de risques éventuels de dommages corporels. Il est nécessaire de respecter tous les messages de sécurité écrits après ce symbole pour éviter toute blessure voire la mort.

▲ DANGER

DANGER indique une situation de danger qui, si elle n'est pas évitée, entraînera la mort ou de graves blessures.

▲ AVERTISSEMENT

AVERTISSEMENT indique une situation de danger qui, si elle n'est pas évitée, peut entraîner la mort ou de graves blessures.

▲ ATTENTION

ATTENTION indique une situation de danger qui, si elle n'est pas évitée, peut entraîner des blessures légères ou modérées.

AVIS

AVIS est utilisé pour indiquer des pratiques non liées à des blessures physiques.

Instructions de sécurité et informations générales

RANGEZ CES INSTRUCTIONS EN LIEU SUR –

Ce manuel contient des consignes importantes à respecter lors de l'installation et de l'entretien de l'onduleur et des accumulateurs.

Inspectez le contenu du paquet à sa réception. Informez le transporteur et le revendeur en cas de dommage constaté.

- Cet onduleur est destiné uniquement à une utilisation à l'intérieur.
- N'utilisez pas cet onduleur s'il est exposé à la lumière directe du soleil, s'il est en contact avec des liquides ou dans des environnements très poussiéreux ou à forte humidité.
- N'utilisez pas l'onduleur à proximité de fenêtres ou de portes ouvertes.
- Assurez-vous que les grilles d'aération de l'onduleur ne sont pas obstruées. Laissez suffisamment d'espace pour une ventilation correcte.

Remarque : Laissez un dégagement minimum de 20 cm sur les quatre côtés de l'onduleur.

- Les facteurs environnementaux influencent la durée de vie des batteries. Elle est raccourcie en cas de températures ambiantes élevées, de mauvaise alimentation secteur et de décharges fréquentes. Suivez les recommandations du fabricant des batteries.
- Branchez directement le câble d'alimentation de l'onduleur dans la prise murale. N'utilisez pas de parasurtenseur ou de rallonge.

Sécurité électrique

- Lorsque la mise à la terre ne peut être vérifiée, déconnectez l'équipement de la prise de secteur avant l'installation ou la connexion à d'autres appareils. Ne rebranchez le cordon d'alimentation qu'après avoir effectué toutes les autres connexions.
- Les connexions à la ligne d'alimentation (secteur) doivent être effectuées par un électricien qualifié.
- La ligne de terre de protection de l'onduleur conduit le courant de fuite provenant des périphériques de la charge (équipement informatique). Un conducteur isolé de mise à la terre doit être installé sur le circuit terminal de l'onduleur. Ce conducteur doit être de même gabarit et isolé avec le même matériau que les conducteurs du circuit terminal avec ou sans terre. Il doit être de couleur verte avec ou sans bande jaune.
- Le câble de terre doit être relié à la terre de l'équipement de service ou, si l'alimentation provient d'un circuit dérivé distinct, à la terre du transformateur ou du générateur d'alimentation correspondant.

Sécurité des batteries

ATTENTION

SULFURE D'HYDROGÈNE GAZEUX ET FUMÉE EXCESSIVE

- Les batteries doivent être remplacées lorsqu'elles atteignent la fin de leur durée de vie.
- Les batteries doivent être remplacées lorsque l'appareil indique que le remplacement des batteries est nécessaire.
- Lors du remplacement des batteries, remplacez-les par des batteries en nombre et de type identiques à celles installées d'origine dans l'unité.

Le non-respect de ces instructions peut entraîner des blessures légères ou modérées et endommager l'équipement.

- Ne jetez pas de batteries dans un feu. Les batteries pourraient exploser.
- N'ouvrez pas et n'altérez pas physiquement les batteries. Une fuite de son électrolyte serait dangereuse pour les yeux et la peau, et il peut être toxique.
- L'entretien des batteries doit être réalisé ou supervisé par un spécialiste connaissant bien les batteries et les précautions requises.
- Schneider Electric utilise des batteries plomb-acide scellées sans entretien. Dans le cadre d'une utilisation et d'une manipulation normales, il n'y a aucun contact avec les composants internes de la batteries. Une surcharge, une surchauffe ou toute autre mauvaise utilisation des batteries peut entraîner une décharge de l'électrolyte des batteries. La solution électrolyte libérée est toxique et peut être dangereuse pour la peau et les yeux.
- **ATTENTION :** Avant de remplacer les batteries, retirez tout bijou en métal, y compris chaînes, bracelets et bagues. Le passage d'une énergie élevée à travers des matériaux conducteurs peut provoquer de graves brûlures.

Avertissement sur les fréquences radioélectriques

Cet appareil est un onduleur de classe C2. Dans un environnement résidentiel, ce produit peut créer des interférences radio, auquel cas l'utilisateur peut être tenu de prendre des mesures adéquates.

Description du produit

L'onduleur Easy UPS d'Schneider Electric est un onduleur (UPS) de haute performance. Un onduleur permet de protéger les équipements électroniques en cas de coupure de courant, de baisse de tension, de sous-tension ou de surtension, aussi bien en cas de petites fluctuations d'alimentation que de fortes perturbations du réseau d'alimentation électrique. L'onduleur fournit en outre une alimentation de secours par batterie, en attendant le retour à un niveau normal de l'alimentation CA ou jusqu'à ce que les batteries soient complètement déchargées.

Ce manuel d'utilisation est également disponible sur le CD de documentation fourni et sur le site Web de Schneider Electric, www.apc.com.

Contenu de l'emballage

Veillez lire le guide de sécurité avant d'installer l'onduleur.

L'emballage est recyclable ; conservez-le donc pour réemploi ou jetez-le conformément à la réglementation en vigueur.

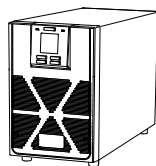

(1)

Onduleur



(1)

Manuel d'utilisation

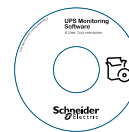

(1)

Logiciel, CD de documentation de l'utilisateur

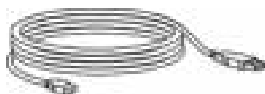

(1)

Câble USB



(1*)

Câble d'alimentation secteur



(1**)

Câble de sortie

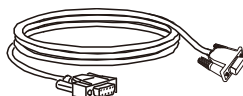

(1)

Câble RS-232

*: en fonction de la fiche d'entrée locale à sélectionner. **: uniquement sur les modèles avec prise CEI (10 A).

REMARQUE : Les numéros de modèle et de série se trouvent sur une petite étiquette située sur le couvercle supérieur.

Accessoires en option

Pour des accessoires optionnels, consultez le site Web d'Schneider Electric, www.apc.com.

Caractéristiques

Spécifications environnementales

AVIS



RISQUE DE DOMMAGES

- L'onduleur ne doit être utilisé qu'à l'intérieur.
- Le lieu de l'installation doit être robuste pour résister au poids de l'onduleur.
- Évitez d'utiliser l'onduleur dans un environnement excessivement poussiéreux ou hors des limites de température ou d'humidité spécifiées.

Le non-respect de ces instructions risque d'endommager l'équipement.

Température	Fonctionnement	0° à 40°C à charge nominale. 40° à 50°C réduit linéairement à 80 % de la capacité de charge maximale.	Le filtre est conçu pour une utilisation en intérieur uniquement. Sélectionnez un endroit stable et pouvant supporter son poids. Évitez d'utiliser l'onduleur dans un environnement excessivement poussiéreux ou hors des limites de température ou d'humidité spécifiées. Remarque : Chargez les batteries tous les 6 mois pendant le stockage.
	Stockage	-20° à 50°C	
Elevation	Fonctionnement	0 à 1 000 m : fonctionnement normal 1 000 - 3 000 m : La charge réduit d'1 % tous les 100 mètres d'augmentation de l'altitude > 3 000 m : L'onduleur ne fonctionnera pas	
	Stockage	0 - 15 000 m	
Humidité		0 à 95 % d'humidité relative, sans condensation	

Caractéristiques physiques

Modèle d'onduleur	SRVS 1000 VA	SRVS 2000 VA	SRVS 3000 VA
Dimensions avec l'emballage Largeur x hauteur x profondeur	235 mm (9,25 pouces) x 330 mm (12,99 pouces) x 365 mm (14,37 pouces)	235 mm (9,25 pouces) x 355 mm (13,98 pouces) x 525 mm (20,67 pouces)	325 mm (12,8 pouces) x 465 mm (18,31 pouces) x 565 mm (22,24 pouces)
Dimensions sans l'emballage Largeur x hauteur x profondeur	145 mm (5,7 pouces) x 223 mm (8,78 pouces) x 288 mm (11,34 pouces)	145 mm (5,7 pouces) x 238 mm (9,37 pouces) x 400 mm (15,75 pouces)	190 mm (7,5 pouces) x 336 mm (13,2 pouces) x 425 mm (16,7 pouces)
Poids avec emballage	10,6 kg	18,1 kg	29 kg
Poids sans emballage	9,3 kg	16,8 kg	26,8 kg
Consignes de levage	<18 kg (<40 lb) 	18 - 32 kg (40 - 70 lb) 	18 - 32 kg (40 - 70 lb) 

Spécifications d'Entrée/Sortie

Modèle d'onduleur		SRVS 1000 VA	SRVS 2000 VA	SRVS 3000 VA
Entrée	Tension	230 Vca nominale		
	Fréquence	40 - 70 Hz		
	Plage de tension d'entrée (charge à 100 %)	160 Vca - 280 Vca		
	Plage de tension d'entrée (charge à 50 %)	110 V CA – 285 V CA		
	Facteur de puissance d'entrée (charge résistive 100 %)	≥ 0,99 en mode économie d'énergie ≥ 0,93 en mode normal		
	Protection d'entrée	Disjoncteur d'entrée		
Sortie	Capacité de l'onduleur	1000 VA / 800 W	2000 VA / 1600 W	3000 VA / 2400 W
	Tension de sortie nominale	230 Vca		
	Autre tension programmable	220 Vca, 240 Vca		
	Efficacité à charge nominale	88 % max.		
	Régulation de la tension de sortie	± 1 % en statique		
	Distorsion de la tension de sortie	<ul style="list-style-type: none"> • 3 % max. pour charge linéaire complète, • 6 % max. pour une charge DDFT complète (100 % VA, 0,8 PF) • 15 % pendant les 60 dernières secondes de la durée de sauvegarde (avec pleine charge uniquement pour la batterie interne) 		
	Fréquence sur batterie	50 Hz ± 0,5 % ou 60 Hz ± 0,5 %		
	Fréquence – Mode CA	50 Hz ± 3 Hz ou 60 Hz ± 3 Hz		
	Facteur de crête	3 : 1		
	Forme d'onde	Onde sinusoïdale		
	Connexion de sortie	Veuillez consulter les caractéristiques du panneau arrière		
	Dérivation	Dérivation interne		

Batterie

Modèle d'onduleur	SRVS 1000 VA	SRVS 2000 VA	SRVS 3000 VA
Configuration	Batterie interne		
Type	Scellée sans entretien (SMF) 12 V, 9 Ah		
Tension du banc de batteries	24 V	48 V	72 V

Panneau d'affichage avant

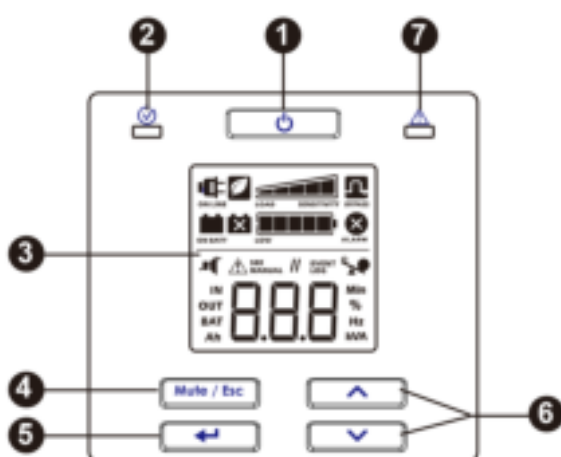

- ❶ Bouton Marche/Arrêt de l'onduleur
- ❷ Voyant d'état
- ❸ Écran LCD
- ❹ Bouton Muet/Échap
- ❺ Bouton Entrée
- ❻ Bouton Haut/Bas
- ❼ Voyant Major Alarm (Alarme)

Fonctions du panneau arrière

SRVS 1000VA

Modèle	Type et quantité de sorties
SRVS1KI	 x 3

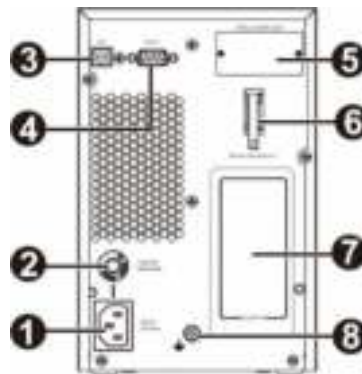

- 1** Entrée CA
- 2** Disjoncteur d'entrée
- 3** Port USB
- 4** RS-232
- 5** Emplacement intelligent pour carte
- 6** Sectionneur de batterie
- 7** Groupe de prises (consulter le type et la quantité de prises sur le côté gauche)
- 8** Vis de mise à la terre

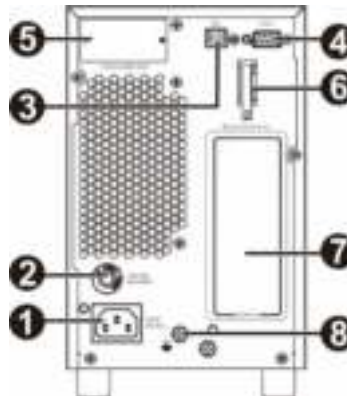

SRVS 2000VA

Modèle	Type et quantité de sorties
SRVS2KI	 x4



- 1** Entrée CA
- 2** Disjoncteur d'entrée
- 3** Port USB
- 4** RS-232
- 5** Emplacement intelligent pour carte
- 6** Sectionneur de batterie
- 7** Groupe de prises (consulter le type et la quantité de prises sur le côté gauche)
- 8** Vis de mise à la terre

SRVS 3000VA

Modèle	Type et quantité de sorties
SRVS3KI	 x6
	 x1

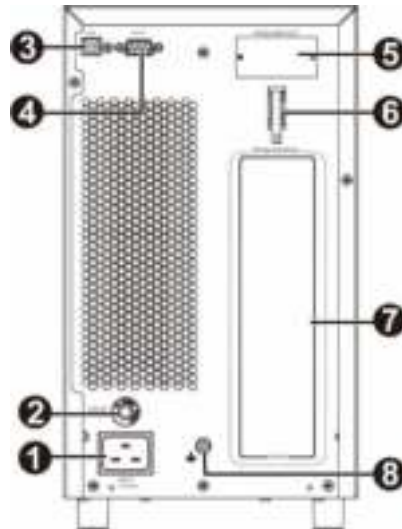

- | | |
|-------------------------------|---|
| 1 Entrée CA | 5 Emplacement intelligent pour carte |
| 2 Disjoncteur d'entrée | 6 Sectionneur de batterie |
| 3 Port USB | 7 Groupe de prises (consulter le type et la quantité de prises sur le côté gauche) |
| 4 RS-232 | 8 Vis de mise à la terre |

Connecteurs de base

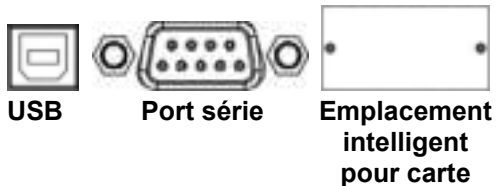

Un logiciel de gestion d'alimentation et des kits d'interface peuvent être utilisés avec l'onduleur.

Utilisez uniquement les kits d'interface fournis ou approuvés par Schneider Electric.

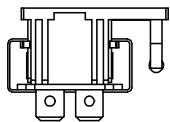

Sectionneur de batterie

Ce onduleur est équipé d'une batterie interne. Pour les batteries sans connexion lorsque l'onduleur est expédié depuis l'usine. Avant d'allumer l'onduleur. Veuillez brancher la batterie en tirant la poignée vers le haut, puis en la poussant dans l'onduleur.

Paramètres de démarrage

Connexion de la batterie

Branchez la batterie en tirant la poignée de la batterie vers le haut, puis en la poussant dans l'onduleur.

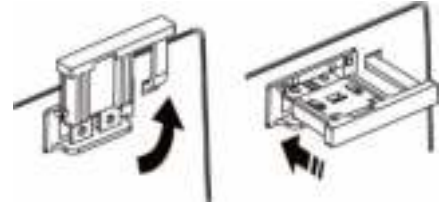

Connexion de l'alimentation et de l'équipement à l'onduleur

⚠ ATTENTION

RISQUE DE CHOC ÉLECTRIQUE

- Tous les travaux électriques doivent être réalisés par un électricien qualifié.
- Mettez cet équipement complètement hors tension avant toute intervention. Effectuez les procédures de consignation.
- Ne portez pas de bijoux lorsque vous utilisez des équipements électriques.

Le non-respect de ces instructions peut entraîner des blessures légères ou modérées.

1. Connectez l'équipement à l'onduleur. Évitez d'utiliser des rallonges.
2. Connectez l'alimentation secteur d'entrée à l'onduleur.
3. Activez l'alimentation secteur d'entrée. Le panneau d'affichage de l'onduleur s'allume ensuite si l'alimentation secteur est disponible.



Faire démarrer le système.

Appuyez sur le bouton  situé sur le panneau avant de l'onduleur.

- La batterie se charge à 90 % de sa capacité lors des cinq premières heures de fonctionnement normal.
- *Ne vous attendez* pas à ce que la batterie fonctionne à sa capacité de maximale pendant la période de chargement initiale.

Démarrage à froid de l'onduleur

Utilisez la fonction de démarrage à froid pour alimenter l'équipement connecté à partir des batteries de l'onduleur.

Appuyez sur le bouton . Le panneau d'affichage s'allume ensuite. Appuyez à nouveau sur le bouton  pour fournir une alimentation par batterie à l'équipement connecté.

Connexion et installation du logiciel de gestion

Easy UPS SRVS est livré avec le logiciel de gestion SchneiderUPS pour l'arrêt automatique du système d'exploitation, la surveillance de l'onduleur, le contrôle de l'onduleur et les relevés énergétiques. Le diagramme suivant est une représentation d'une installation serveur type.

1. Connectez le câble USB depuis l'arrière de l'onduleur à l'appareil protégé, tel qu'un serveur.
2. Pour un serveur ou un autre appareil avec un système d'exploitation, chargez le CD SchneiderUPS et suivez les instructions de configuration à l'écran.
3. Un port série intégré est également disponible pour des options de communication supplémentaires avec un câble série.
4. Encore plus d'options de communication sont disponibles via l'emplacement intelligent pour carte intégrée. Consultez le site www.apc.com pour plus d'informations.

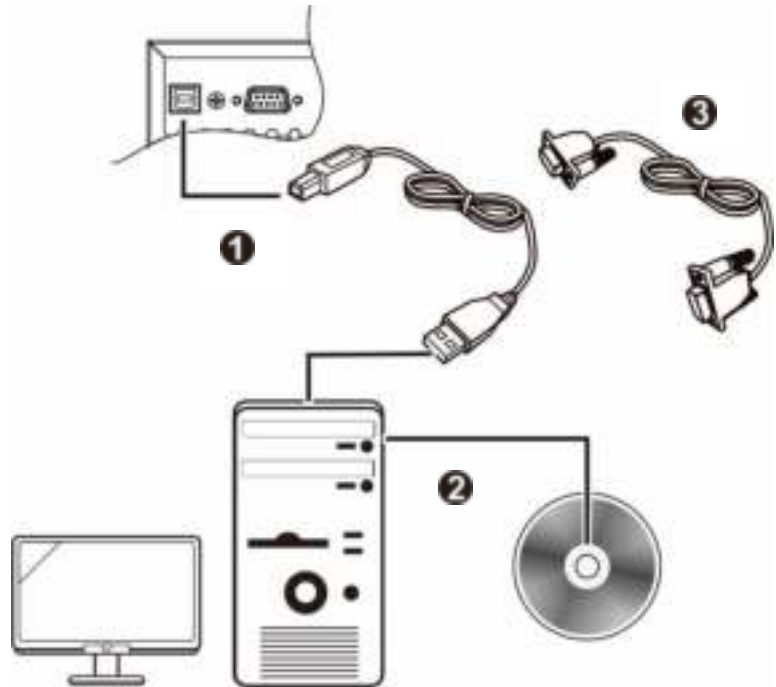







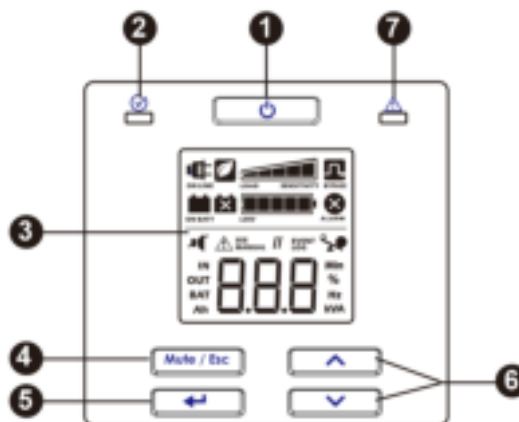

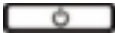
Fonctionnement









Utilisation de l'affichage

Ces modèles Easy UPS sont équipés d'un écran LCD intuitif et configurable. Cet écran complète l'interface logicielle car les deux communiquent des informations similaires et peuvent être utilisés pour configurer les paramètres de l'onduleur. L'écran comprend les touches et les indicateurs suivants :



1	Bouton Marche/Arrêt de l'onduleur 	<ul style="list-style-type: none"> ● Appuyez sur ce bouton pour mettre en marche l'onduleur. ● Appuyez sur ce bouton et maintenez-le enfoncé jusqu'à ce qu'un bip soit émis pour arrêter l'onduleur. ● Appuyez sur ce bouton pour réinitialiser les alarmes.
2	Voyant d'état 	<p>Le voyant LED Statut s'allume en vert sous tension. Ce voyant LED indique deux états différents d'alimentation de sortie :</p> <ul style="list-style-type: none"> ● Sortie désactivée : Le voyant LED clignote. Appuyez sur le bouton Marche/Arrêt pour activer l'alimentation de sortie. ● Sortie alimentée : Le voyant LED s'allume en vert en continu.
3	Écran LCD	<p>Les options de l'interface d'affichage sont visibles sur cet écran LCD. Appuyez sur le bouton  ou  pour activer l'écran LCD, si l'écran n'est pas éclairé.</p>
4	Bouton Muet/Échap 	<ul style="list-style-type: none"> ● Pour acquitter les alarmes sonores et les supprimer temporairement. ● Pour quitter un sous-menu et revenir au menu principal.
5	Bouton Entrée 	Appuyez sur ce bouton pour accéder au menu ou pour sélectionner un élément/une valeur du menu pendant la navigation.
6	Bouton Haut/Bas  	Appuyez sur ces deux boutons pour faire défiler les options du menu principal et les écrans d'affichage.
7	Voyant Major Alarme 	Ce voyant LED Alarme s'allume en rouge lorsque l'onduleur détecte une erreur et clignote en rouge pour les notifications de l'onduleur. Voir "Alarmes et notifications" en page 11 de ce manuel.

Icônes de l'écran LCD

 ON LINE	Sur secteur : L'onduleur utilise l'alimentation secteur et réalise une double conversion pour alimenter l'équipement connecté.
 ON BATT	Sur batterie : L'onduleur alimente les équipements connectés sur batterie.
	Remplacement de la batterie : La batterie n'est pas bien raccordée ou la batterie est proche de la fin de sa durée de vie et doit être remplacée.
 BYPASS	Dérivation : L'onduleur est en mode Shunt et transfère directement le courant de secteur à l'équipement connecté. Le fonctionnement en mode de dérivation est le résultat d'un événement interne à l'onduleur ou d'une surcharge. Le fonctionnement sur batterie n'est pas disponible tant que l'onduleur est en mode Dérivation. Voir "Alarmes et notifications" en page 11 de ce manuel. Cette icône combinée à l'icône du mode Économie d'énergie, indique que l'onduleur fonctionne en mode économie d'énergie.
 ALARM	Alarmes système : Une défaillance interne est détectée. Voir "Alarmes et notifications" en page 11 de ce manuel.
	Surcharge : Les équipements connectés à l'onduleur utilisent une alimentation supérieure à l'alimentation nominale.
 LOW	Charge de la batterie : Le niveau de charge de la batterie est indiqué par le nombre de barres illuminées. Lorsque les cinq blocs sont illuminés, la batterie est complètement chargée. Chaque barre représente environ 20 % de la capacité de charge de la batterie.
 LOAD SENSITIVITY	Niveau de charge : Le pourcentage de charge est indiqué par le nombre de barres de charge illuminées. Chaque barre représente environ 20 % de la capacité de charge maximale.
	Muet : Une ligne illuminée à travers l'icône indique que l'alarme sonore est désactivée.



Mode économie d'énergie : Une icône allumée indique que l'onduleur fonctionne en mode Économie d'énergie. L'équipement connecté reçoit l'entrée secteur directement tant que la tension et la fréquence d'entrée sont dans les limites configurées.



Alarme ou notification : L'onduleur a détecté une erreur ou l'onduleur est en mode configuration. Voir "Alarmes et notifications" en page 11 de ce manuel.

EVENT LOG



Événement : L'icône s'allume lorsque l'utilisateur visualise le journal des événements.

Alarmes et erreurs système

Voyants d'état

Bips continus, toutes les demi-secondes	État Batterie faible - La batterie approche de son état de décharge complète. L'onduleur est sur le point de s'arrêter.
4 bips toutes les 30 secondes (le premier bip commence après 4 secondes sur batterie)	Surcharge - Les équipements connectés à l'onduleur utilisent une alimentation supérieure à l'alimentation nominale.
Avertisseur sonore continuellement en marche	État Sur batterie - L'onduleur fournit une alimentation de secours sur batterie aux équipements connectés.
Bip bref toutes les 2,5 secondes	État Alarme - L'onduleur a détecté une erreur. Voir "Alarmes et notifications" dans ce manuel.
Bips brefs continus toutes les demi-secondes pendant 1 minute, se répète toutes les 5 heures.	Batterie déconnectée.
Deux bips brefs toutes les 5 secondes	Batterie défectueuse (remplacer)
	État Dérivation sur événement - L'onduleur a détecté une erreur. L'équipement connecté reçoit l'alimentation d'entrée secteur via le relais de dérivation.

Alarmes

Code à l'écran	Description	Solution
SC	L'onduleur a subi un court-circuit à la sortie. L'onduleur va essayer de reprendre automatiquement à partir de cette condition.	Vérifiez la présence d'un court-circuit à la sortie de l'onduleur. Supprimez le court-circuit, attendez que l'onduleur reprenne automatiquement ou appuyez sur le bouton  pour démarrer l'onduleur. Remarque : L'alimentation fournie à l'équipement connecté est réduite lorsque l'onduleur est dans cette condition.
OL	L'onduleur connaît une surcharge.	Déconnectez l'équipement non indispensable de l'onduleur pour éliminer la surcharge.
dCH	L'onduleur a détecté une erreur de tension CC. L'onduleur va essayer de reprendre automatiquement à partir de cette condition.	Si l'onduleur ne reprend pas automatiquement, contactez Schneider Electric.
Hot	La température de l'onduleur augmente au-delà des limites fixées.	Déconnectez les équipements non indispensables de l'onduleur pour réduire la charge de l'onduleur. Assurez-vous que la température ambiante est dans les limites. Assurez-vous qu'un dégagement adéquat est conservé.
CH9	L'onduleur a détecté une erreur du chargeur.	Vérifiez la présence d'un court-circuit à la borne de la batterie de l'onduleur. Appuyez sur le bouton  pour démarrer l'onduleur.

Contactez Schneider Electric pour tous les autres codes d'alarme.

Notifications

Code à l'écran	Description	Solution
bdc	La batterie n'est pas connectée.	Connectez la batterie à l'onduleur. Voir "Démarrage" en page 8 de ce manuel.

Paramètres d'affichage de l'onduleur

Les données opérationnelles affichées dans le panneau d'affichage sont présentées dans le tableau.













Naviguez avec le bouton  ou .

Paramètre	Unités	Icônes d'indication
Tension de sortie	Vca	SORTIE, V
Fréquence de sortie	Hz	SORTIE, Hz
Tension d'entrée	Vca	ENTRÉE, V
Fréquence d'entrée	Hz	ENTRÉE, Hz
Tension de la batterie	V CC	BAT, V
Température ambiante	° C	NOMBRE, C
État de la charge de la batterie	%	BAT, %
Niveau de charge en pourcentage (Maximum de Watts ou de VA)	%	SORTIE, %
Niveau de charge en kVA	kVA	SORTIE, kVA
Capacité totale en Ah de la batterie connectée	Ah	BAT, Ah
Autonomie de fonctionnement restante sur batterie	minutes	BAT, Min

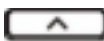
Configuration

Configurer les paramètres de l'onduleur

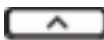
Procédez comme suit pour configurer les paramètres de l'onduleur :



1. Appuyez sur le bouton .
2. Appuyez sur le bouton  ou  pour naviguer jusqu'à "Régler".
3. Appuyez sur le bouton .
4. Naviguez dans les paramètres avec le bouton  ou .
5. Appuyez sur le bouton  pour éditer un paramètre. Les icônes commencent à clignoter pour indiquer l'édition.
6. Appuyez sur le bouton  ou  pour naviguer entre les options disponibles pour le paramètre sélectionné.
7. Appuyez sur le bouton  pour sélectionner l'option ou sur le bouton  pour annuler l'édition du paramètre actuel. Le clignotement des icônes s'arrête après.
8. Appuyez sur le bouton  ou  pour naviguer entre les paramètres.
9. Appuyez sur le bouton  pour quitter la navigation dans le menu.















Paramètres de l'onduleur

Configurez les paramètres de l'onduleur à l'aide de l'interface d'affichage. Voir la section "Configurer les paramètres de l'onduleur" pour éditer les paramètres.

Fonction	Valeur par défaut	Options sélectionnables par l'utilisateur	Description
Tension de sortie	230 Vca	220, 230, 240 Vca	Permet à l'utilisateur de sélectionner la tension de sortie pendant que l'onduleur fonctionne en ligne.
Alarme sonore	Activer	Activer, désactiver	L'onduleur désactive les alarmes sonores lorsque désactiver est sélectionné ou lorsque le bouton MUET du panneau d'affichage est actionné.
Mode économie d'énergie/mode haute efficacité	Désactivé	Activer/Désactiver	Lorsque ce mode est activé, l'équipement connecté reçoit l'alimentation d'entrée secteur via le relais de dérivation tant que la tension d'entrée se situe dans le plage de $\pm 5\%$ de la tension de sortie configurée et ± 3 Hz de la fréquence de sortie configurée. L'inverseur est désactivé dans ce mode. Si l'alimentation d'entrée secteur sort de la plage, l'inverseur est activé. La charge est transférée au mode en ligne ou au mode batterie. L'alimentation de l'équipement connecté peut être interrompue jusqu'à 10 millisecondes.
Paramètre Capacité minimum de la batterie pour redémarrer	0 %	0 %, 15 %, 50 %, 90 %,	La sortie de l'onduleur ne sera pas activée tant que la batterie ne sera pas chargée à un niveau lui permettant de fournir l'autonomie de fonctionnement configurée par ce réglage. Si elle est configurée à 0 %, la sortie de l'onduleur est activée immédiatement après le retour de l'alimentation secteur.
Paramètre Indication de l'état batterie faible	2 min	2 min, 5 min, 7 min, 10 min	L'onduleur émet une alarme sonore lorsque la durée de fonctionnement réelle atteint la limite fixée par l'utilisateur final. L'alarme sonore n'est émise que lorsque l'onduleur fonctionne en mode batterie.

Navigation avancée dans l'affichage



Il existe cinq options dans le menu principal et deux options de sous-menu dans l'affichage de l'onduleur. Appuyez sur le bouton  depuis l'écran d'accueil pour accéder à ces options de menu. Utilisez le bouton  ou  pour naviguer entre les options du menu.

Option de menu	Description
SET	<p>Configuration de l'onduleur Utilisez cette option du menu pour configurer les paramètres de l'onduleur. Appuyez sur le bouton  pour visualiser les options de configuration. Voir "Configurer les paramètres de l'onduleur" page 13 pour plus de détails. Appuyez sur le bouton  pour retourner à l'écran d'accueil.</p>
LOG	<p>Afficher le journal des événements Utilisez cette option du menu pour visualiser le journal des événements de l'onduleur. L'onduleur enregistre les 10 derniers événements et affiche les codes dans ce journal. Appuyez sur le bouton  pour visualiser le journal. Utilisez le bouton  ou  pour visualiser les événements enregistrés. Le bouton  permet de naviguer vers les anciens événements et le bouton  permet de naviguer vers les nouveaux événements. Toutes les entrées du journal disposent d'un code d'événement numérique et textuel. À la fin du journal, le mot "Fin" est affiché. Appuyez sur le bouton  pour retourner à l'écran d'accueil.</p>
UPS	<p>Afficher les informations de l'onduleur Utilisez cette option du menu pour visualiser les informations de l'onduleur. Appuyez sur le bouton  pour visualiser les valeurs nominales de l'onduleur. Appuyez sur le bouton  pour visualiser la version de firmware de l'onduleur. Appuyez sur le bouton  pour retourner à l'écran d'accueil.</p>
bYP	<p>Commande utilisateur de dérivation Utilisez cette option du menu pour commuter l'onduleur en mode dérivation ou passer l'onduleur en mode en ligne depuis le mode dérivation. Appuyez sur le bouton  :</p> <p>Put : Utilisez-le pour commuter l'onduleur en mode de fonctionnement en dérivation. Remarque : L'alimentation de l'équipement connecté est réduite si la tension secteur n'est pas dans les valeurs limites. Sortie : Sort l'onduleur de la dérivation et restaure une alimentation stable pour l'équipement connecté.</p>
tSt	<p>Exécuter le test automatique de batterie Utilisez cette option du menu pour effectuer un test automatique et déterminer le statut de la batterie. Appuyez sur le bouton  pour lancer le test. Si la commande de test est acceptée, l'onduleur lance un test automatique et démarre un compte à rebours à l'écran. Les messages à l'écran sont affichés à la fin du test.</p> <p>rFd : Test refusé. La sortie est à l'arrêt ou la batterie n'est pas chargée. Fl d : Test non réussi PAS : Test réussi Abt : Le test est annulé pour des raisons internes</p> <p>Appuyez sur le bouton  pour retourner à l'écran d'accueil</p>

Dépannage

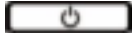
Utilisez le tableau ci-dessous pour résoudre les problèmes mineurs d'installation et de fonctionnement. Reportez-vous au site Web de Schneider Electric, www.apc.com, pour obtenir de l'assistance en cas de problèmes complexes d'onduleur.

Problème et/ou cause possible	Solution
L'onduleur ne se met pas en marche lorsque l'entrée secteur est disponible ou il n'y a pas d'alimentation en sortie	
L'onduleur n'est pas allumé.	Appuyez sur le bouton  pour mettre l'onduleur sous tension.
L'onduleur n'est pas connecté à l'alimentation secteur.	Assurez-vous que les deux extrémités du câble d'alimentation reliant l'onduleur à l'alimentation secteur sont connectées. Voir "Démarrage" en page 8 de ce manuel.
Le disjoncteur thermique d'entrée de l'onduleur est déclenché.	Appuyez sur le bouton de réinitialisation du disjoncteur thermique d'entrée sur le panneau arrière.
L'onduleur fonctionne sur batterie tout en étant connecté à l'alimentation secteur.	
La tension ou la fréquence d'entrée est haute, basse ou instable.	Branchez l'onduleur à une autre prise sur un autre circuit. Testez la tension d'entrée pour vérifier que l'onduleur est alimenté. Si l'écran est allumé, naviguez et vérifiez la tension et la fréquence d'entrée.
Lorsqu'il est connecté à la batterie, l'onduleur n'alimente pas l'équipement connecté	
L'onduleur n'est pas allumé.	Si l'onduleur s'est éteint (l'écran n'est pas allumé), suivez la procédure "Démarrage à froid de l'onduleur" en page 8.
La batterie n'est pas connectée.	Connectez la batterie à l'onduleur. Voir "Démarrage" en page 8 de ce manuel.
Coupure sur batterie faible. L'onduleur a peut-être déchargé la batterie en raison d'une coupure de courant secteur et désactivé la sortie en raison de la condition de batterie faible.	Attendez le retour de l'alimentation secteur et chargez la batterie. Pour activer l'alimentation de sortie après le retour de l'alimentation secteur, appuyez sur le bouton  .
Alarme sonore à intervalles espacés	
L'onduleur fonctionne normalement sur batterie.	L'onduleur a détecté une erreur. Voir "Alarmes et notifications" en page 11 de ce manuel.
Le voyant LED d'alarme est allumé. L'onduleur affiche un message d'alarme et émet un bip constant.	
L'onduleur a détecté une erreur.	Voir "Alarmes et notifications" en page 11 de ce manuel.
Aucun son audible provenant de l'onduleur même lorsque le voyant LED Alerte est allumé.	
L'alarme sonore est désactivée.	Modifiez la configuration de l'onduleur pour autoriser les alarmes sonores.
L'onduleur n'assure pas l'alimentation de secours très longtemps.	
La batterie de l'onduleur est déchargée en raison d'une coupure de courant récente.	Les batteries doivent être rechargées après des coupures prolongées. Les batteries peuvent s'user plus rapidement en cas de mise en service sans recharge appropriée ou de fonctionnement à des températures élevées.
La batterie est proche de la fin de sa durée de vie.	Si la batterie arrive à la fin de sa vie, pensez à la remplacer même si le voyant de la batterie n'est pas encore allumé. Voir "Démarrage" en page 8 de ce manuel.

Problème et/ou cause possible	Solution
L'onduleur ne s'éteint pas	
Le bouton ARRÊT n'est pas actionné correctement	Appuyez sur le bouton  et maintenez-le enfoncé jusqu'à ce que le bip soit émis pour mettre l'onduleur hors tension.
L'alimentation d'entrée secteur est disponible.	L'alimentation logique de l'onduleur ne peut pas être désactivée si l'alimentation d'entrée secteur est disponible. Pour arrêter l'onduleur, coupez l'alimentation d'entrée secteur et appuyez sur le bouton  . Relâchez lorsqu'un bip est émis.
L'onduleur est en mode dérivation et le voyant LED n'est pas allumé en rouge.	
L'onduleur est en mode économie d'énergie.	Désactivez le mode économie d'énergie s'il n'est pas souhaité.
L'onduleur est configuré pour rester en mode dérivation.	Modifiez la configuration pour quitter le mode dérivation.
L'onduleur est en mode dérivation même après avoir acquitté l'alarme de surchauffe.	Réduisez la charge connectée à < 90 % pour passer l'onduleur en mode en ligne.
L'onduleur a connu une surcharge et a été transféré sur la dérivation.	L'équipement connecté dépasse la "charge maximale" définie dans les spécifications sur le site Web d'Schneider Electric, www.apc.com . L'alarme persiste jusqu'à la correction de la surcharge. Déconnectez l'équipement non indispensable de l'onduleur pour éliminer la surcharge. Tant qu'il est en mode dérivation et que le disjoncteur ne se déclenche pas, l'onduleur continue de fournir de la puissance. En cas de coupure de tension secteur, l'onduleur ne fournira pas d'alimentation sur batterie.
L'onduleur a détecté une erreur et a été transféré sur la dérivation.	Voir "Alarmes et notifications" en page 11 de ce manuel.

Transport

1. Mettez hors tension et déconnectez tous les équipements connectés.
2. Débranchez l'appareil de l'alimentation secteur.
3. Déconnectez toutes les batteries internes et externes (le cas échéant).
4. Suivez les instructions d'expédition indiquées à la section *Service après-vente* de ce manuel.

Service après-vente

Si l'équipement nécessite un entretien, ne le retournez pas au revendeur. Procédez de la manière suivante :

1. Consultez la section *Dépannage* de ce guide pour résoudre les problèmes courants.
2. Si le problème persiste, contactez l'assistance clients d'Schneider Electric par le biais du site web, **www.apc.com**.
 - a. Notez le numéro de modèle, le numéro de série et la date d'achat. Vous trouverez les numéros de modèle et de série sur le panneau arrière de l'onduleur et sur l'écran LCD (selon modèle).
 - b. Appelez le service client. Un technicien tentera de résoudre le problème par téléphone. Si ce n'est pas possible, le technicien vous attribuera un numéro RMA (retour de produits défectueux).
 - c. Si l'onduleur est sous garantie, les réparations sont gratuites.
 - d. Les procédures de réparation et de retour peuvent varier selon les pays. Pour obtenir des instructions spécifiques à un pays, consultez le site Web d'Schneider Electric, **www.apc.com**.
3. Emballez l'appareil correctement afin d'éviter tout dommage pendant le transport. N'utilisez jamais de billes de polystyrène pour l'emballage.
Les dommages causés par le transport ne sont pas couverts par la garantie.
Remarque : Avant l'expédition, débranchez toujours tous les modules de batteries d'un onduleur ou bloc-batterie externe.
Les batteries internes débranchées peuvent rester dans l'onduleur ou dans le pack de batterie externe.
4. Inscrivez le numéro RMA sur l'extérieur du carton.
5. Retournez l'onduleur à l'adresse indiquée par l'assistance clients, en prenant soin de l'assurer et en port payé.

Garantie usine limitée

Schneider Electric IT Corporation (SEIT) garantit que ses produits seront exempts de tous défauts dus au matériel ou à la fabrication pendant une période de deux (2) ans à compter de la date d'achat. L'obligation de SEIT en vertu de cette garantie est limitée à la réparation ou au remplacement, à sa seule discrétion, de tels produits défectueux. La réparation ou le remplacement d'un produit défectueux ou d'un de ses composants ne prolonge pas la période de garantie d'origine.

Cette garantie ne s'applique qu'à l'acheteur d'origine qui doit avoir dûment enregistré le produit dans un délai de dix jours maximum après son achat. L'enregistrement du produit peut se faire en ligne à l'adresse warranty.apc.com.

Dans le cadre de cette garantie, SEIT ne peut être tenu responsable si, après contrôle et examen par SEIT, il s'avère que le produit n'est pas défectueux ou que le défaut présumé est la conséquence d'une mauvaise utilisation, d'une négligence, d'une mauvaise installation ou d'une utilisation incorrecte de la part de l'utilisateur final ou d'un tiers, contrairement aux recommandations des spécifications de SEIT. SEIT ne peut en outre être tenu pour responsable de défauts résultant de : 1) tentative non autorisée de réparation ou de modification du produit, 2) tension du secteur ou connexion au secteur incorrecte ou inadaptée, 3) conditions d'utilisation inappropriées sur les lieux, 4) catastrophe naturelle, 5) exposition aux éléments naturels ou 6) vol. SEIT ne peut en aucun cas être tenu responsable au titre de cette garantie pour tout produit dont le numéro de série a été modifié, effacé ou enlevé.

SAUF STIPULATION CONTRAIRE CI-DESSUS, CE CONTRAT NE FOURNIT AUCUNE GARANTIE, EXPLICITE OU IMPLICITE, PAR EFFET DE LA LOI OU DE TOUTE AUTRE MANIERE, CONCERNANT LES PRODUITS VENDUS, REPARÉS OU FOURNIS.

SEIT REJETTE TOUTE GARANTIE IMPLICITE DE QUALITE MARCHANDE, DE SATISFACTION ET D'ADEQUATION A UN USAGE PARTICULIER.

LES GARANTIES EXPLICITES DE SEIT NE PEUVENT ETRE ETENDUES, DIMINUEES OU AFFECTEES PAR LES CONSEILS OU SERVICES TECHNIQUES OU AUTRES OFFERTS PAR SEIT CONCERNANT LES PRODUITS, ET AUCUNE OBLIGATION OU RESPONSABILITE NE PEUT S'EN DEGAGER.

LES PRÉSENTS RECOURS ET GARANTIES SONT EXCLUSIFS ET PRIMENT SUR TOUS LES AUTRES RECOURS ET GARANTIES. EN CAS DE NON-RESPECT DE CES GARANTIES, LA RESPONSABILITÉ DE SEIT ET LE RECOURS DE L'ACHETEUR SE LIMITENT AUX GARANTIES INDIQUÉES CI-DESSUS. LES GARANTIES OCTROYÉES PAR SEIT S'APPLIQUENT UNIQUEMENT À L'ACHETEUR ET NE SONT PAS TRANSFÉRABLES À UN TIERS.

EN AUCUN CAS, SEIT, SES AGENTS, SES DIRECTEURS, SES FILIALES OU SES EMPLOYÉS NE POURRONT ÊTRE TENUS RESPONSABLES POUR TOUTE FORME DE DOMMAGES INDIRECTS, PARTICULIERS, IMMATERIELS OU EXEMPLAIRES, SUITE À L'UTILISATION, L'ENTRETIEN OU L'INSTALLATION DES PRODUITS, QUE CES DOMMAGES REVETENT UN CARACTÈRE CONTRACTUEL OU DELICTUEL, SANS TENIR COMPTE DES DÉFAUTS, DE LA NEGLIGENCE OU DE LA RESPONSABILITÉ ABSOLUE, OU MEME SI SEIT A ÉTÉ PRÉVENU DE L'ÉVENTUALITÉ DE TELS DOMMAGES. SPÉCIFIQUEMENT, SEIT N'EST RESPONSABLE D'AUCUN COUT, TEL QUE LA PERTE DE PROFITS OU DE REVENUS (DIRECTE OU INDIRECTE), LA PERTE DE MATÉRIEL, LA PERTE DE L'UTILISATION DE MATÉRIEL, LA PERTE DE LOGICIELS OU DE DONNÉES, LE COUT DE SUBSTITUTS, LES RECLAMATIONS PAR DES TIERS OU AUTRES.

CETTE GARANTIE NE VISE NULLEMENT À EXCLURE OU LIMITER LA RESPONSABILITÉ DE SEIT EN CAS D'ACCIDENT GRAVE, VOIRE MORTEL RÉSULTANT D'UNE NÉGLIGENCE OU D'UNE INFORMATION FAUSSE DE SA PART, DANS LA MESURE OÙ UNE TELLE RESPONSABILITÉ NE PEUT ÊTRE EXCLUE OU LIMITÉE PAR LA LOI EN VIGUEUR.

Pour obtenir une réparation sous garantie, il est nécessaire d'obtenir un numéro RMA (retour de produits défectueux) auprès de l'assistance clients. Les clients désirant effectuer une réclamation peuvent accéder à l'assistance clients internationale de SEIT sur le site Web d'Schneider Electric à l'adresse : www.apc.com. Sélectionnez votre pays dans le menu déroulant. Ouvrez l'onglet Support en haut de la page Web pour obtenir des informations sur l'assistance clients dans votre région. Les produits doivent être renvoyés en port payé et doivent être accompagnés d'une brève description du problème ainsi que de la preuve et du lieu d'achat.

Assistance clientèle mondiale d'Schneider Electric

Le service clientèle pour ce produit ou tout autre produit de Schneider Electric est disponible gratuitement des manières suivantes :

- Consultez le site Web de Schneider Electric pour accéder aux documents de la base de connaissances de Schneider Electric et soumettre vos demandes d'assistance.
 - **www.apc.com** (Siège social)
Connectez-vous aux sites web locaux pour chaque pays de Schneider Electric, qui contiennent des informations relatives à l'assistance clients.
 - **www.apc.com/support/**
Assistance internationale grâce à la base de connaissances de Schneider Electric et via e-support.
- Contactez un centre d'assistance clients Schneider Electric par téléphone ou par courrier électronique.
 - Centres locaux, relatifs à un pays : consultez le site **www.apc.com/support/contact** pour en savoir plus.

Pour plus d'informations sur comment obtenir le support du service clientèle, contactez le représentant Schneider Electric ou le revendeur qui vous a fourni votre produit Schneider Electric.

Manual del Usuario - Easy UPS En-Linea Serie SRVS de 1000VA, 2000VA y 3000VA

Información de seguridad importante

Lea las instrucciones cuidadosamente e inspeccione el equipo para familiarizarse con el dispositivo antes de intentar instalarlo, ponerlo en funcionamiento o realizar reparaciones o el mantenimiento. Los siguientes mensajes especiales pueden aparecer a lo largo de este documento o en el equipo para advertirle sobre posibles peligros o para atraer su atención sobre información que explica o simplifica algún procedimiento.



La incorporación de este símbolo en una etiqueta de Peligro o Advertencia de seguridad del producto, indica que existe un peligro eléctrico que provocará lesiones personales si no se siguen las instrucciones.



Este es el símbolo de alerta de seguridad. Se utiliza para alertarle sobre posibles peligros de lesiones personales. Obedezca todos los mensajes de seguridad que sigan a este símbolo para evitar posibles lesiones o la muerte.

PELIGRO

PELIGRO indica una situación peligrosa que, de no evitarse, provocará lesiones graves o la muerte.

ADVERTENCIA

ADVERTENCIA indica una situación peligrosa que, de no evitarse, podría provocar lesiones graves o la muerte.

PRECAUCIÓN

PRECAUCIÓN indica una situación peligrosa que, de no evitarse, podría provocar lesiones leves o moderadas.

AVISO

AVISO utilizado para abordar prácticas no relacionadas con lesiones físicas.

Información general y de seguridad

GUARDE ESTAS INSTRUCCIONES –

Este manual contiene instrucciones importantes que deben seguirse durante la instalación y mantenimiento del SAI y las baterías.

Inspeccione el contenido del embalaje después de recibirlo. Si observa daños, informe a su distribuidor y a la compañía de transporte.

- Este SAI está diseñado únicamente para uso en interiores.
- No utilice este SAI en una ubicación en la que reciba la luz directa del sol, ni en contacto con líquidos ni en un entorno con polvo excesivo o mucha humedad.
- No utilice el SAI cerca de ventanas o puertas abiertas.
- Asegúrese de que los orificios de ventilación del SAI no estén obstaculizados. Deje suficiente espacio para una ventilación adecuada.

Nota: Deje una distancia de seguridad mínima de 20 cm en los cuatro lados del SAI.

- Los factores ambientales afectan la vida útil de las baterías. Las altas temperaturas ambiente, una escasa calidad de la alimentación de la red eléctrica y las descargas frecuentes disminuyen la vida útil de la batería. Siga las recomendaciones del fabricante de la batería.
- Conecte el cable de alimentación del SAI directamente a una toma de pared. No utilice extensiones eléctricas ni protectores contra sobretensiones.

Seguridad eléctrica

- Cuando no sea posible verificar la conexión a tierra, desconecte el equipo del tomacorriente de la red eléctrica antes de instalarlo o conectarlo a otro equipo. Vuelva a conectar el cable eléctrico sólo después de realizar todas las demás conexiones.
- La conexión al circuito secundario (red de alimentación principal) debe ser efectuada por un electricista calificado.
- El conductor a tierra de protección para el SAI transporta la corriente de fuga de los dispositivos conectados al SAI (equipos de cómputo y de red). Se debe instalar un conductor a tierra aislado, como parte del circuito secundario que alimenta al SAI. El conductor debe ser del mismo tamaño y tener el mismo material aislante que los conductores de alimentación de los circuitos secundarios con y sin toma a tierra. El conductor que se instale será verde, con o sin una banda amarilla.
- El conductor a tierra debe estar conectado a tierra en el equipo del servicio o, si es alimentado desde un sistema derivado por separado, en el transformador de alimentación o en el motor-generador o planta eléctrica.

Seguridad de las baterías

PRECAUCIÓN

GAS DE SULFURO DE HIDRÓGENO Y HUMO EXCESIVO

- Se deberá reemplazar la batería cuando alcance el final de su vida útil.
- Se deberán reemplazar las baterías cuando la unidad indica que es necesario reemplazar las baterías.
- Al reemplazar las baterías, sustitúyalas por otras del mismo tipo y la misma cantidad que las baterías instaladas originalmente en la unidad.

De no seguir estas instrucciones, se pueden producir lesiones leves o moderadas y daños al equipo.

- No arroje las baterías al fuego. Las baterías pueden explotar.
- No abra o mutile las baterías. El electrolito liberado es perjudicial para la piel y los ojos, y puede ser tóxico.
- El mantenimiento de las baterías debe llevarlo a cabo o supervisarlos personal con conocimiento sobre las baterías y tomando las precauciones necesarias.
- Schneider Electric utiliza baterías selladas de plomo ácido que no requieren mantenimiento. Durante el uso y la manipulación normal, no existe contacto con los componentes internos de las baterías. Una sobrecarga, sobrecalentamiento u otro uso indebido de las baterías podría causar una descarga de los electrolitos de la batería. La exposición al electrolito es tóxica y podría ser perjudicial para la piel y los ojos.
- **PRECAUCIÓN:** Antes de sustituir las baterías, quítese cualquier tipo de objeto como cadenas, relojes de muñeca o anillos que pueda ser conductor. Una corriente elevada circulando por un material conductor puede provocar quemaduras graves.

Advertencia sobre radiofrecuencia

Este es un producto SAI de categoría C2. En un entorno residencial, este producto puede provocar interferencias de radio, en cuyo caso puede ser necesario que el usuario tome las medidas adecuadas.

Descripción del producto

El Easy UPS de Schneider Electric es un sistema de alimentación ininterrumpida (SAI (también conocido como UPS)) de alto rendimiento. El SAI ofrece protección para equipos electrónicos contra apagones totales y parciales del suministro de energía de la red eléctrica, caídas de tensión, sobretensiones y pequeñas y grandes fluctuaciones de la red. El SAI también suministra alimentación de respaldo de la batería a los equipos conectados hasta que el suministro de alimentación de la red eléctrica se restablezca a niveles normales o hasta que las baterías se descarguen completamente.

Este manual del usuario está disponible en el CD de documentación incluido con el SAI, y en el sitio Web de Schneider Electric en www.apc.com.

Contenido del embalaje

Lea la Guía de Seguridad antes de instalar el SAI.

El material de embalaje es reciclable, guárdelo para volver a usarlo o deséchelo de forma adecuada.

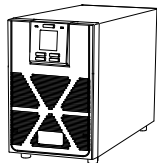

(1)
SAI



(1)
Manual de usuario



(1)
CD de software y
documentación del usuario

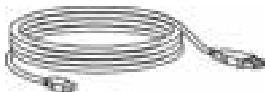

(1)
Cable USB



(1*)
Cable de alimentación de la red
eléctrica



(1**)
Cable de salida

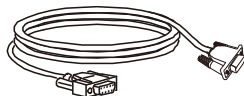

(1)
Cable RS-232

*: seleccione en base a la toma local para conectar el SAI.

** : Solo para los modelos con toma de corriente IEC (10 A).

NOTA: Los números de modelo y serie se encuentran en una pequeña etiqueta en la tapa superior o en la parte posterior.

Accesorios opcionales

Para los accesorios opcionales, consulte el sitio web de Schneider Electric en www.apc.com.

Especificaciones

Especificaciones del entorno

AVISO



RIESGO DE DAÑO AL EQUIPO

- El SAI se debe utilizar solamente en interiores.
- La ubicación de instalación debe ser resistente para soportar el peso del SAI.
- No haga funcionar el SAI si hay demasiado polvo o si la temperatura o la humedad están fuera de los límites especificados.

De no seguir estas instrucciones se pueden causar daños en el equipo.

Temperatura	Operacion	De 0° a 40 °C con la carga nominal. De 40° a 50 °C con reducción lineal al 80 % de la capacidad de carga máxima.	Esta unidad está diseñada únicamente para el uso en interiores. Seleccione una ubicación que sea suficientemente resistente para soportar el peso. No haga funcionar el SAI si hay demasiado polvo o si la temperatura o la humedad están fuera de los límites especificados. Nota: Cargue los módulos de baterías cada seis meses durante el almacenamiento.
	Almacenamiento	De -20° a 50 °C	
Altitud	Operacion	0 - 1000 m: funcionamiento normal 1000 - 3000 m: La carga se reduce un 1 % cada vez que la altura aumenta 100 m > 3000 m: El SAI no funcionará	
	Almacenamiento	0 - 15 000 m	
Humedad		De 0 a 95 % de humedad relativa, sin condensación	

Especificaciones físicas

Modelo de SAI	SRVS 1000VA	SRVS 2000VA	SRVS 3000VA
Dimensiones con embalaje Ancho x Alto x Profundidad	235 mm (9,25 pulgadas) x 330 mm (12,99 pulgadas) x 365 mm (14,37 pulgadas)	235 mm (9,25 pulgadas) x 355 mm (13,98 pulgadas) x 525 mm (20,67 pulgadas)	325 mm (12,8 pulgadas) x 465 mm (18,31 pulgadas) x 565 mm (22,24 pulgadas)
Dimensiones sin embalaje Ancho x Alto x Profundidad	145 mm (5,7 pulgadas) x 223 mm (8,78 pulgadas) x 288 mm (11,34 pulgadas)	145 mm (5,7 pulgadas) x 238 mm (9,37 pulgadas) x 400 mm (15,75 pulgadas)	190 mm (7,5 pulgadas) x 336 mm (13,2 pulgadas) x 425 mm (16,7 pulgadas)
Peso con embalaje	10,6 kg	18,1 kg	29 kg
Peso sin embalaje	9,3 kg	16,8 kg	26,8 kg
Directivas para levantar el equipo de forma segura	<18 kg (<40 lb) 	18 - 32 kg (40 - 70 libras) 	18 - 32 kg (40 - 70 libras) 

Especificaciones de entrada y salida

Modelo de SAI	SRVS 1000VA	SRVS 2000VA	SRVS 3000VA	
Entrada	Voltaje			
	230 Vca Nominal			
	Frecuencia			
	40 – 70 Hz			
	Intervalo de tensión de entrada (100 % de carga)			
	160 Vca - 280 Vca			
Intervalo de tensión de entrada (50 % de carga)				
110 Vca - 285 Vca				
Factor de potencia de entrada (100 % de carga resistiva)				
≥ 0,99 en modo Ecológico ≥ 0,93 en modo Normal				
Protección de entrada				
Disyuntor de entrada				
Salida	Capacidad del SAI	1000 VA / 800 W	2000 VA / 1600 W	3000 VA / 2400 W
	Voltaje de salida nominal	230 Vca		
	Otra tensión programable	220 Vca, 240 Vca		
	Eficiencia con carga nominal	88 % máx.		
	Regulación de tensión de salida	± 1 % estática		
	Distorsión de tensión de salida	<ul style="list-style-type: none"> • 3 % máx. para carga lineal total, • 6 % máx. para carga RCD total (VA al 100 %, FP de 0,8) • 15 % para los últimos 60 segundos del tiempo de respaldo (con carga total solo para la batería interna) 		
	Frecuencia - En Batería	50 Hz ± 0,5 % o 60 Hz ± 0,5 %		
	Frecuencia - Modo CA	50 Hz ± 3 Hz o 60 Hz ± 3 Hz		
	Factor de cresta	3:1		
	Forma de onda	Onda senoidal		
	Conexión de salida	Consulte las características del panel posterior		
	Derivación	Derivación interna		

Batería

Modelo de SAI	SRVS 1000VA	SRVS 2000VA	SRVS 3000VA
Configuración	Batería interna		
Tipo	Sellada libre de mantenimiento ("SMF, Sealed Maintenance Free") 12 V y 9 Ah		
Tensión de la batería externa	24 V	48 V	72 V

Panel indicador delantero

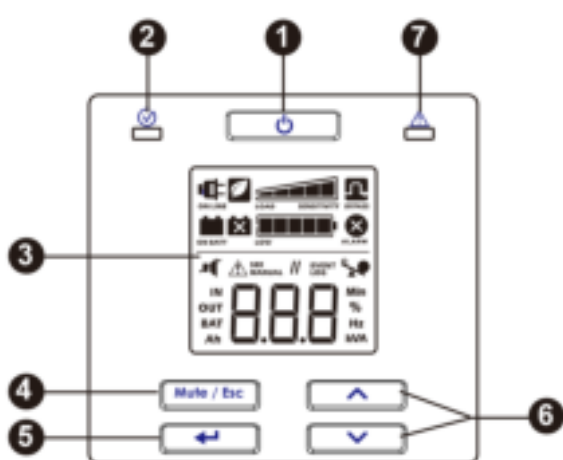

- 1 Botón de encendido y apagado del SAI
- 2 LED de estado
- 3 Pantalla LCD
- 4 Botón Silencio/Salir
- 5 Botón Entrar/Aceptar
- 6 Botón Arriba y Abajo
- 7 LED de alarma

Características del panel posterior

SRVS 1000VA

Modelo	Cantidad y tipo de salidas
SRVS1KI	 x 3

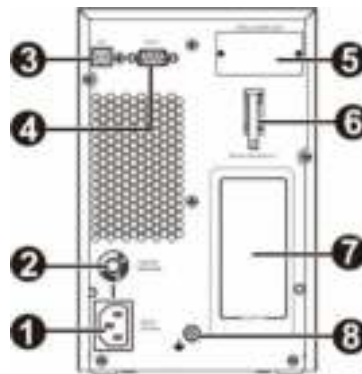

- | | |
|-------------------------------|--|
| 1 Entrada de CA | 5 Ranura para tarjeta inteligente |
| 2 Disyuntor de entrada | 6 Conector de conexión/desconexión de la batería interna |
| 3 Puerto USB | 7 Grupo de tomas de salida (consulte la cantidad y tipo de salidas en la tabla a mano izquierda) |
| 4 RS-232 | 8 Tornillo de conexión a tierra |

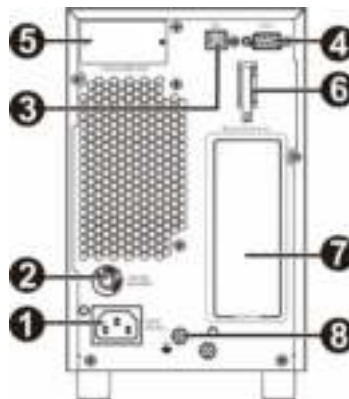

SRVS 2000VA

Modelo	Cantidad y tipo de salidas
SRVS2KI	 x4



- | | |
|-------------------------------|--|
| 1 Entrada de CA | 5 Ranura para tarjeta inteligente |
| 2 Disyuntor de entrada | 6 Conector de conexión/desconexión de la batería interna |
| 3 Puerto USB | 7 Grupo de tomas de salida (consulte la cantidad y tipo de salidas en la tabla a mano izquierda) |
| 4 RS-232 | 8 Tornillo de conexión a tierra |

SRVS 3000VA

Modelo	Cantidad y tipo de salidas
SRVS3KI	 x6
	 x1

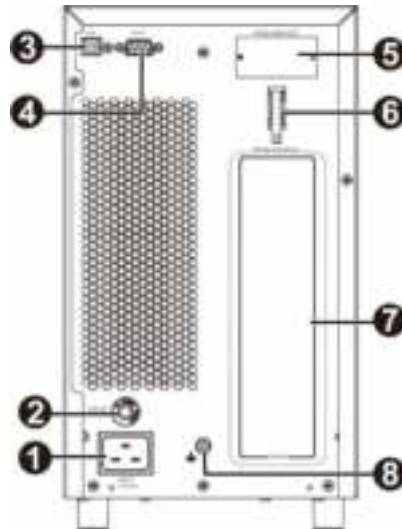

- | | | | |
|----------|----------------------|----------|--|
| 1 | Entrada de CA | 5 | Ranura para tarjeta inteligente |
| 2 | Disyuntor de entrada | 6 | Conector de conexión/desconexión de la batería interna |
| 3 | Puerto USB | 7 | Grupo de tomas de salida (consulte la cantidad y tipo de salidas en la tabla a mano izquierda) |
| 4 | RS-232 | 8 | Tornillo de conexión a tierra |

Conectores Básicos

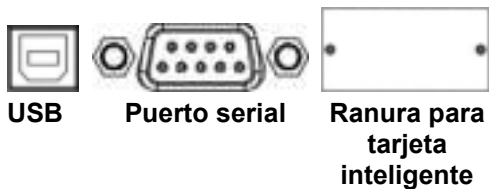

Se pueden usar programas de gestión de energía y accesorios y tarjetas de comunicaciones con el SAI.

Utilice sólo los accesorios y las tarjetas de comunicaciones suministrados o aprobados por Schneider Electric.

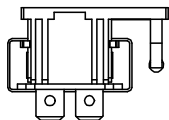

Conector de conexión/desconexión de la batería interna

Este SAI cuenta con batería interna. La batería interna no está conectada cuando el SAI se envía de la fábrica. Antes de encender el SAI, conecte la batería interna tirando del asa del conector hacia arriba y, después, empuje el conector hacia el interior de la unidad.

Parámetros de arranque

Conexión de la batería

Conecte la batería tirando del asa del conector hacia arriba y, después, empúje el conector hacia el interior de la unidad.

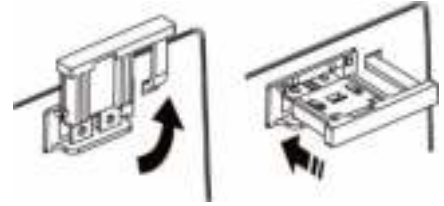

Conexión de la electricidad y el equipo al SAI

⚠ PRECAUCIÓN

PELIGRO DE DESCARGA ELÉCTRICA

- Todo el trabajo eléctrico debe ser realizado por un electricista calificado.
- Desconecte toda la alimentación eléctrica de este equipo antes de trabajar en él. Practique los procedimientos de cierre y etiquetado.
- No lleve ningún objeto de joyería cuando trabaje con equipos eléctricos.

De no seguir estas instrucciones, se pueden producir lesiones leves o moderadas.

1. Conecte el equipo al SAI. No use cables de extensión.
2. Conecte la alimentación de la red eléctrica al SAI.
3. Encienda el suministro eléctrico de entrada. A continuación, el panel de la pantalla del SAI se iluminará cuando la alimentación esté disponible.



Encendido del SAI

Presione el botón  ubicado en el panel frontal del SAI.

- La batería se carga al 90 % de su capacidad durante las primeras cinco horas de funcionamiento normal.
- **No** espere un funcionamiento completo 'con energía de la batería' durante este período de carga inicial.



Arranque en frío del SAI

Utilice la característica de arranque en frío para suministrar energía al equipo conectado utilizando las baterías del SAI (si no hay o no ha encendido el suministro eléctrico).

Presione el botón . A continuación, el panel de la pantalla se iluminará. Presione el botón  de nuevo para suministrar energía de la batería al equipo conectado.

Conectar e instalar el software de administración

Easy UPS SRVS se proporciona con el software de administración SchneiderUPS que permite apagar el sistema operativo de forma automática y desentendida, monitorear el SAI, y controlar y crear informes del consumo energético del SAI. El siguiente diagrama es una representación de una instalación típica de un servidor.

1. Conecte el cable USB desde la parte posterior del SAI  al dispositivo protegido, como puede ser un servidor.
2. Para un servidor u otro dispositivo con un sistema operativo, cargue el CD de SchneiderUPS y siga las instrucciones de configuración que aparezcan en la pantalla.
3. También hay disponible un puerto serial integrado  que ofrece otras opciones de comunicación mediante un cable serial.

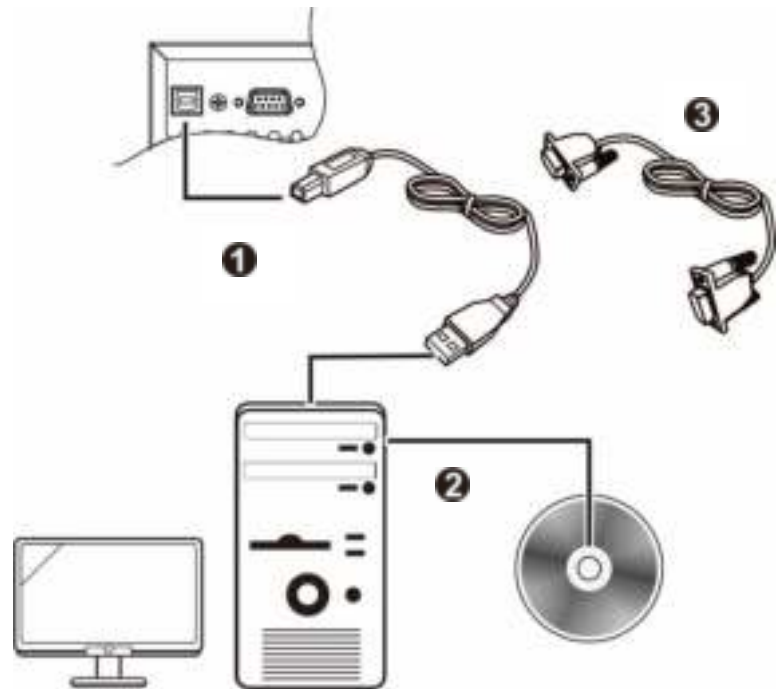







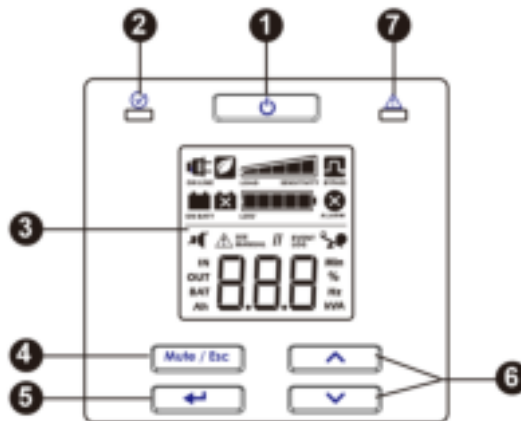

4. Hay incluso más opciones de comunicación disponibles a través de la ranura para tarjeta inteligente. Consulte el sitio web www.apc.com para obtener más información.

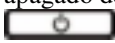
Operación









Uso de la pantalla

Estos modelos Easy UPS cuentan con una pantalla LCD intuitiva y configurable. Esta pantalla complementa a la interfaz de software, ya que transmite información similar y se puede utilizar para definir la configuración del SAI. La pantalla incluye los siguientes botones e indicadores:



1	Botón de encendido y apagado del SAI 	<ul style="list-style-type: none"> ● Presione este botón para encender el SAI. ● Presione sin soltar este botón hasta que se escuche un pitido para apagar el SAI. ● Presione este botón para restablecer las alarmas.
2	LED de estado 	<p>El LED de estado se ilumina en verde cuando la alimentación está encendida. Este LED indica dos estados diferentes de alimentación de salida:</p> <ul style="list-style-type: none"> ● Salida desactivada: El LED parpadea. Presione el botón de encendido y apagado para activar la alimentación de salida. ● Salida activada: El LED se ilumina en verde continuamente.
3	Pantalla LCD	Las opciones de interfaz de la pantalla está visibles en esta pantalla LCD. Presione el botón  o  para activar la pantalla LCD si esta no se ilumina.
4	Botón Silencio/Esc 	<ul style="list-style-type: none"> ● Para reconocer alarmas audibles y suprimirlas temporalmente. ● Para salir de un submenú y volver al menú principal.
5	Botón Entrar 	Presione este botón para entrar en el menú o seleccionar un valor o elemento de submenú durante la navegación.
6	Botón Arriba y Abajo  	Presione estos dos botones para recorrer las opciones del menú principal y las pantallas de visualización.
7	LED de alarma 	Este LED de alarma se ilumina en rojo cuando el SAI detecta un error y parpadea en rojo durante las notificaciones del SAI. Consulte la sección “Alarmas y notificaciones” en la página 11 de este manual.

Iconos de la pantalla LCD

 ON LINE	En línea: El SAI obtiene alimentación de la red eléctrica y realiza una doble-conversión para suministrar energía al equipo conectado.
 ON BATT	Funcionamiento con la batería: El SAI suministra energía de respaldo de la batería al equipo conectado.
 REEMPLAZAR BATERÍA	Reemplazar batería: La batería no está conectada de forma segura o se aproxima al final de su vida útil y se debe cambiar.
 BYPASS	Bypass: El SAI está en modo de desvío ("bypass") y suministra energía de la red eléctrica directamente al equipo conectado. El modo de desvío es el resultado de un evento interno del SAI o de una condición de sobrecarga. El respaldo de la batería no está disponible cuando el SAI se encuentra en el modo de desvío. Consulte la sección “Alarmas y notificaciones” en la página 11 de este manual. Este icono junto con el icono Modo Ecológico, indica que el SAI está funcionando en modo ecológico.
 ALARM	Alarmas del sistema: Error interno detectado. Consulte la sección “Alarmas y notificaciones” en la página 11 de este manual.
	Sobrecarga: El equipo conectado al SAI está consumiendo más energía que la nominal.
 LOW	Carga de la batería: El nivel de carga de la batería está indicado por el número de secciones que se encienden. Cuando los cinco bloques están encendidos, la batería del SAI está totalmente cargada. Cada barra representa aproximadamente un 20% de la capacidad de carga de la batería.
 LOAD SENSITIVITY	Nivel de carga: El porcentaje de carga está indicado por el número de secciones de la barra de carga que se iluminan. Cada barra representa aproximadamente un 20% de la capacidad de carga máxima del SAI.
	Silenciar: La línea que atraviesa el icono se enciende para indicar que las alarmas audibles se han desactivado.



Modo verde: El icono iluminado indica que la unidad está funcionando en modo Ecológico. El equipo conectado recibe alimentación de la red principal directamente siempre que el voltaje y la frecuencia de entrada se encuentren dentro de los límites configurados.



Alarma o notificación: El SAI ha detectado un error o se encuentra en modo de configuración. Consulte la sección “Alarmas y notificaciones” en la página 11 de este manual.

EVENT LOG



Evento: El icono se ilumina cuando el usuario está viendo el registro de eventos.

Alarmas y errores del sistema

Indicadores de Estado

Pitidos continuos cada medio segundo.	Estado de batería baja: La batería está llegando al estado de descarga completa. El SAI está a punto de apagarse.
	Condición de sobrecarga: El equipo conectado al SAI está consumiendo más energía que la nominal.
4 pitidos cada 30 segundos (el primer pitido se inicia después de 4 segundos con batería)	Estado de operacion con la batería: El SAI suministra energía de respaldo de la batería al equipo conectado.
Pitido continuamente activado	Estado de alarma: El SAI ha detectado un error. Consulte la sección “Alarmas y notificaciones” de este manual.
Pitido corto cada 2,5 segundos	Batería desconectada.
Pitidos breves continuos cada medio segundo durante 1 minuto, repeticiones cada 5 horas.	Batería mala (reemplazar)
Dos pitidos cortos cada 5 segundos	Estado de desvio ("bypass") por un evento: El SAI ha detectado un error. Los equipos conectados reciben energía de entrada de la red eléctrica a través del relé de desvio ("bypass").

Alarmas

Código de pantalla	Descripción	Solución
SC	El SAI ha experimentado un cortocircuito ("Short Circuit") a la salida. La unidad intentará recuperarse automáticamente de esta condición.	Compruebe si hay un cortocircuito a la salida del SAI. Quite el cortocircuito y espere a que la unidad se recupere automáticamente o presione el botón  para iniciar el SAI. Nota: No se suministra energía al equipo conectado cuando el UPS está en este estado.
OL	El SAI se encuentra en un estado de sobrecarga ("OverLoad").	Para eliminar la condición de sobrecarga, desconecte del SAI todos los equipos que no sean esenciales.
dCH	El SAI detectó un error interno de voltaje/corriente directa (CD). La unidad intentará recuperarse automáticamente de esta condición.	Si el SAI no se recupera automáticamente, póngase en contacto con Schneider Electric.
Hot	La temperatura de la unidad está subiendo por encima de los límites establecidos.	Para reducir la carga del SAI, desconecte de este todos los equipos que no sean esenciales. Asegúrese de que la temperatura ambiente se encuentra dentro de los límites. Asegúrese de que la distancia de seguridad alrededor del SAI cumple con el mínimo requerido.
CH9	El SAI detectó un error en el cargador.	Verifique si hay un cortocircuito en el terminal de la batería del SAI. Presione el botón  para iniciar el SAI.



Póngase en contacto con Schneider Electric para todos los demás códigos de alarma.

Notificaciones

Código de pantalla	Descripción	Solución
bdc	La batería no está conectada.	Conecte la batería del SAI. Consulte la sección “Arranque” en la página 8 de este manual.

Parámetros de visualización del SAI

Los datos de funcionamiento mostrados en el panel de visualización se proporcionan en la tabla.











Navegue utilizando el botón  o .

Parámetro	Unidades	Iconos del indicador
Voltaje de salida	Vca	SALIDA, V
Frecuencia de salida	Hz	SALIDA, Hz
Voltaje de entrada	Vca	ENTRADA, V
Frecuencia de entrada	Hz	ENTRADA, Hz
Voltaje de la batería	V CD	BAT, V
Temperatura ambiente	°C	NÚMERO, C
Estado de carga de la batería	%	BAT, %
Nivel de carga en porcentaje (cantidad máxima de vatios o VA)	%	SALIDA, %
Nivel de carga en kVA	kVA	SALIDA, kVA
Capacidad Ah total de la batería conectada	Ah	BAT, Ah
Tiempo de autonomía restante con batería	Minutos	BAT, Min

Configuración

Configure los parámetros del SAI

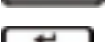
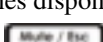
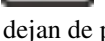
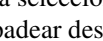
Siga los pasos para configurar los parámetros del SAI:



1. Presione el botón .
2. Presione el botón  o  para ir a “Establecer/Ajustar”.
3. Presione el botón .
4. Recorra los parámetros mediante el botón  o .
5. Presione el botón  para editar un parámetro. Los iconos comienzan a parpadear para indicar la edición.
6. Presione el botón  o  para recorrer las opciones disponibles para el parámetro seleccionado.
7. Presione el botón  para seleccionar la opción o el botón  para anular la edición del parámetro actual. Los iconos dejan de parpadear después de esto.
8. Presione el botón  o  para recorrer los parámetros.
9. Presione el botón  para salir de la navegación del menú.



















Parámetros del SAI

Defina la configuración del SAI mediante la interfaz de visualización. Consulte la sección “Configurar los parámetros del SAI” para editar los parámetros.

Función	Valor predeterminado de fábrica	Opciones que puede seleccionar el usuario	Descripción
Voltaje de salida	230 Vca	220, 230, 240 VCA	Permite al usuario seleccionar el voltaje de salida mientras el SAI está operando en línea.
Alarma Audible	Activar	Activar, desactivar	El SAI silenciará las alarmas audibles cuando se fije en Deshabilitar o cuando se presione el botón SILENCIO del panel de visualización.
Modo Ecológico/ modo de alta eficiencia	Desactivado	Activar/desactivar	Cuando este modo está habilitado, el equipo conectado recibe la alimentación de entrada de la red eléctrica a través del relé de desvío ("bypass") siempre que el voltaje de entrada se encuentre dentro del intervalo de $\pm 5\%$ del voltaje de salida configurado y ± 3 Hz de la frecuencia de salida configurada. El inversor está desactivado durante este modo. Si la alimentación de la red eléctrica se sale del intervalo, el inversor se activa. La carga se transfiere al modo en línea o al modo de batería. La alimentación al equipo conectado se puede interrumpir hasta 10 milisegundos.
Capacidad mínima de la batería para reiniciar la configuración	0 %	0 %, 15 %, 50 % y 90 %	La salida del SAI no se activará hasta que la batería esté cargada a un nivel tal que pueda proporcionar el tiempo de funcionamiento definido por esta configuración. Si se configura en 0 %, la salida del SAI se activa inmediatamente cuando se reestablezca la alimentación de la red eléctrica.
Configuración de la indicación del estado de batería baja	2 min	2 min, 5 min, 7 min, 10 min	El SAI emitirá una alarma audible cuando el tiempo de autonomía real alcance el límite establecido por el usuario final. La alarma audible solamente se emitirá cuando el SAI funcione en el modo de batería.

Navegación avanzada por la pantalla



Hay cinco opciones en el menú principal y dos opciones de submenú en la pantalla del SAI. Presione el botón  desde la pantalla Inicio para acceder a estas opciones de menú. Utilice el botón  o  para recorrer las opciones de menú.

Opción de menú	Descripción
SET	<p>Configurar el SAI Utilice esta opción de menú para configurar los parámetros del SAI. Presione el botón  para ver las opciones de configuración. Consulte la sección “Configurar los parámetros del SAI” en la página 13 para obtener detalles. Presione el botón  para regresar a la pantalla Inicio.</p>
LOG	<p>Mostrar el registro de eventos Utilice esta opción de menú para ver el registro de eventos del SAI. El SAI graba los últimos 10 eventos y muestra los códigos en este registro. Presione el botón  para ver el registro. Utilice el botón  o  para ver los eventos registrados. El botón  permite navegar hacia los eventos mas viejos y el botón  hacia los eventos mas recientes. Todas las entradas del registro tienen un código de evento numérico y de texto. Al final del registro, se mostrará la palabra “Fin”. Presione el botón  para regresar a la pantalla Inicio.</p>
UPS	<p>Mostrar información del SAI Utilice esta opción de menú para ver la información del SAI. Presione el botón  para ver la clasificación del SAI. Presione el botón  para ver la versión de firmware del SAI. Presione el botón  para regresar a la pantalla Inicio.</p>
bYP	<p>Comando de usuario para desvío ("bypass") Utilice esta opción del menú para cambiar el SAI al modo de desvío ("bypass") o activar el modo en-línea del SAI cuando este se encuentra en el modo de desvío. Presione el botón :</p> <p>Poner: Se utiliza para cambiar el SAI al modo de operación de desvío ("bypass"). Nota: La alimentación al equipo conectado se desconectara si el voltaje de la red eléctrica no se encuentra dentro de los límites de umbral establecido. Salida: Saca al SAI del estado de desvío y restaura la energía limpia en el equipo conectado.</p>
tSt	<p>Ejecutar prueba automática de la batería Utilice esta opción de menú para llevar a cabo una prueba automática y determinar el estado de la batería. Presione el botón  para iniciar la prueba. Si el comando de prueba se acepta, el SAI iniciará una prueba automática y un conteo regresivo en la pantalla. Los mensajes se muestran al final de la prueba en la pantalla.</p> <p> Prueba rechazada. La salida está desactivada o la batería no está cargada.  Prueba no superada  Prueba superada  Prueba anulada por motivos internos</p> <p>Presione el botón  para regresar a la pantalla Inicio.</p>

Resolución de problemas

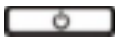
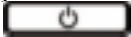
Use la tabla que hallará a continuación para resolver problemas sencillos en la instalación y el funcionamiento. Si necesita ayuda para resolver problemas más complejos con el SAI, consulte el sitio web de Schneider Electric en Internet: www.apc.com.

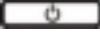
Problema y/o posible causa	Solución
El SAI no se enciende cuando la entrada de la red eléctrica está disponible o no hay salida de alimentación	
El SAI no se enciende.	Pulse el botón  para encender el SAI.
El SAI no está conectado al suministro de energía de la red eléctrica.	Compruebe que el cable eléctrico que conecta el SAI al suministro de energía de la red eléctrica esté firmemente conectado en ambos extremos. Consulte la sección “Arranque” en la página 8 de este manual.
Se activó el disyuntor térmico de entrada del SAI.	Presione el botón de restablecimiento del disyuntor de circuito térmico de entrada situado en el panel posterior.
El SAI está operando con la batería, mientras sigue conectado al suministro de alimentación de entrada de la red eléctrica	
El voltaje o la frecuencia de entrada es alta, baja o está distorsionada.	Enchufe el SAI a una toma de corriente diferente que se encuentre en otro circuito. Pruebe la alimentación de entrada de la red eléctrica para comprobar que la unidad reciba alimentación de entrada. Si la pantalla está encendida, revise el voltaje y la frecuencia de entrada y compruébelas.
El SAI, cuando está conectado a la batería, no suministra alimentación al equipo conectado	
El SAI no se enciende.	Si el SAI se ha apagado (la pantalla no está encendida), siga el procedimiento “Arranque en frío del UPS” en la página 8.
La batería no está conectada.	Conecte la batería al SAI. Consulte la sección “Arranque” en la página 8 de este manual.
Apagado por batería baja. La batería del SAI puede haberse descargado debido a un corte de alimentación de la red eléctrica y desactivó la salida debido a una condición de batería baja.	Espera a que la alimentación de la red eléctrica vuelva y cargue la batería. Para activar la alimentación de salida después de que la alimentación de la red eléctrica vuelva, presione el botón  .
El SAI emite un pitido a intervalos prolongados	
El SAI funciona con normalidad cuando opera con la batería.	El SAI detectó un error. Consulte la sección “Alarmas y notificaciones” en la página 11 de este manual.
LED de alarma iluminado. El SAI muestra un mensaje de alarma y emite un pitido constante	
El SAI ha detectado un error.	Consulte la sección “Alarmas y notificaciones” en la página 11 de este manual.
No hay sonidos audibles procedentes del SAI incluso cuando el LED Alerta está iluminado.	
La alarma audible está deshabilitada.	Cambie la configuración del SAI para habilitar las alarmas audibles.
El SAI no ofrece el tiempo de respaldo previsto.	
La batería del SAI se ha descargado debido a un corte reciente de la alimentación.	Las baterías se deben recargar después de interrupciones prolongadas en el suministro de la red eléctrica. Las baterías se pueden agotar más rápido si se usan sin cargarse adecuadamente o cuando se usan a temperaturas elevadas.
La batería se aproxima al final de su vida útil.	Si la batería está cerca del final de su vida útil, puede ser aconsejable sustituirla aunque todavía no se haya encendido el indicador de reemplazo de la batería. Consulte la sección “Arranque” en la página 8 de este manual.

Problema y/o posible causa	Solución
El SAI no se apaga	
El botón de APAGADO no se presiona correctamente	Presione sin soltar el botón  hasta que se escuche un pitido para apagar el SAI.
La alimentación de entrada de la red eléctrica está disponible.	La alimentación lógica del SAI no se puede desactivar si la alimentación de entrada de la red eléctrica está disponible. Para apagar el SAI, apague la alimentación de entrada de la red eléctrica y presione el botón  . Suéltelo cuando escuche un pitido.
El SAI se encuentra en el modo de desvío ("bypass") y el LED no se ilumina en rojo.	
El SAI se encuentra en modo ecológico.	Deshabilite el modo ecológico si no lo quiere.
El SAI se ha configurado para permanecer en el modo de desvío ("bypass").	Cambie la configuración para salir del modo de desvío.
El SAI se encuentra en el modo de desvío ("bypass") incluso después de hacer desaparecer la alarma de temperatura.	Reduzca la carga conectada a menos de 90 % para activar el modo en línea del SAI.
El SAI ha experimentado una condición de sobrecarga y se transferirá al modo de desvío ("bypass").	El equipo conectado supera la "carga máxima" definida en las especificaciones del sitio web de Schneider Electric: www.apc.com . La alarma permanecerá activada hasta que la condición de sobrecarga desaparezca. Para eliminar la sobrecarga, desconecte del SAI todos los equipos que no sean esenciales. El SAI continuará suministrando energía mientras esté en el modo de desvío y el disyuntor del circuito de entrada no se active. El SAI no suministrará energía de la batería si se produce una interrupción en el voltaje de la red eléctrica.
El SAI detectó un error y se transfirió al modo de desvío ("bypass").	Consulte la sección "Alarmas y notificaciones" en la página 11 de este manual.

Transporte

1. Apague y desconecte todos los equipos conectados.
2. Desconecte la unidad de la red de suministro eléctrico.
3. Desconecte todas las baterías internas y externas (si aplica).
4. Siga las instrucciones para el envío que se indican en la sección *Servicio técnico* de este manual.

Servicio técnico

Si la unidad requiere servicio técnico, no la devuelva al distribuidor. Siga los pasos descritos a continuación:

1. Repase la sección *Resolución de problemas* del manual del SAI para resolver problemas comunes.
2. Si el problema continúa, póngase en contacto con el servicio de atención al cliente de Schneider Electric desde el sitio web de Schneider Electric en **www.apc.com**.
 - a. Anote el número de modelo, el número de serie y la fecha de compra. Los números de modelo y serie figuran en el panel posterior de la unidad y también pueden consultarse en la pantalla LCD de algunos modelos determinados.
 - b. Comuníquese con el servicio de atención al cliente. Un técnico intentará resolver el problema por teléfono. Si no es posible, el técnico emitirá un Número de Autorización para la Devolución de Materiales (RMA#).
 - c. Si la unidad se encuentra en garantía, la reparación es gratuita.
 - d. Los procedimientos de servicio técnico o devolución pueden variar según el país. Consulte las instrucciones específicas para cada país en el sitio web de Schneider Electric: **www.apc.com**
3. Embale la unidad correctamente para evitar que se dañe durante el transporte. No use nunca bolitas de espuma para el embalaje.

Los daños producidos durante el transporte no están cubiertos por la garantía.

Nota: Antes del envío, siempre desconecte los módulos de batería o módulo de baterías externas del SAI. Las baterías internas desconectadas pueden permanecer dentro del SAI o módulo de baterías externas.
4. Escriba el N.º de RMA proporcionado por el Servicio de atención al cliente, en la parte exterior del paquete.
5. Envíe la unidad asegurada y con gastos de transporte prepagados a la dirección indicada por el servicio de atención al cliente.

Garantía limitada de fábrica

Schneider Electric IT Corporation (SEIT) garantiza que sus productos estarán libres de defectos de materiales y mano de obra durante un período de dos (2) años a partir de la fecha de compra. De acuerdo con esta garantía, la obligación de SEIT se limita a reparar o reemplazar, a su absoluta discreción, cualquier producto defectuoso. La reparación o sustitución de un producto defectuoso o parte del mismo no amplía el período de garantía original.

La garantía se otorga únicamente al comprador inicial, quien debe haber registrado correctamente el producto dentro de los 10 días de realizada la compra. Los productos se pueden registrar en línea en warranty.apc.com.

SEIT no será responsable en virtud de esta garantía si las pruebas y exámenes que pudiera realizar indican que el presunto defecto del producto no existe o es consecuencia del uso indebido, negligencia, instalación o realización de pruebas indebidas, o un funcionamiento o uso del producto que infrinja las recomendaciones de especificaciones de SEIT por parte del usuario final o cualquier otro tercero. Además, SEIT no será responsable por defectos resultantes de: 1) intentos no autorizados de reparar o modificar el producto, 2) conexión o tensiones eléctricas incorrectas o inadecuadas, 3) condiciones operativas inadecuadas en el sitio de instalación, 4) casos fortuitos, 5) exposición a los elementos o 6) robo. En ningún caso SEIT será responsable en virtud de esta garantía de ningún producto en el que el número de serie ha sido alterado, desfigurado o retirado.

EXCEPTO LO EXPUESTO ANTERIORMENTE, NO SE OTORGA GARANTÍA ALGUNA, EXPLÍCITA O IMPLÍCITA, POR APLICACIÓN DE LA LEY O DE CUALQUIER OTRA FORMA, A PRODUCTOS VENDIDOS, SUMINISTRADOS O QUE SEAN OBJETO DE OPERACIONES DE SERVICIO EN CUMPLIMIENTO DE ESTE ACUERDO O EN RELACIÓN CON EL PRESENTE.

SEIT NIEGA TODA GARANTÍA IMPLÍCITA DE COMERCIABILIDAD, SATISFACCIÓN Y ADECUACIÓN PARA UN FIN ESPECÍFICO.

LAS GARANTÍAS EXPRESAS DE SEIT NO SE AMPLIARÁN NI REDUCIRÁN, NI SE VERÁN AFECTADAS POR FACTOR ALGUNO Y NO SURGIRÁ OBLIGACIÓN NI RESPONSABILIDAD ALGUNA POR LA PRESTACIÓN DE SERVICIOS TÉCNICOS O DE OTRO TIPO O EL ASESORAMIENTO TÉCNICO O DE OTRO CARÁCTER EN RELACIÓN CON LOS PRODUCTOS.

LAS GARANTÍAS Y RECURSOS PRECEDENTES TIENEN CARÁCTER EXCLUSIVO Y PREVALECE SOBRE TODAS LAS DEMÁS GARANTÍAS Y RECURSOS. LAS GARANTÍAS DETALLADAS ANTERIORMENTE CONSTITUYEN LA RESPONSABILIDAD EXCLUSIVA DE SEIT Y EL RECURSO EXCLUSIVO DE LOS COMPRADORES EN CUANTO A CUALQUIER INCUMPLIMIENTO DE DICHAS GARANTÍAS. LAS GARANTÍAS DE SEIT CUBREN SOLAMENTE AL COMPRADOR ORIGINAL Y NO CUBREN A TERCERO ALGUNO.

SEIT, SUS REPRESENTANTES, DIRECTORES, AFILIADOS Y EMPLEADOS NO SERÁN RESPONSABLES EN NINGÚN CASO POR NINGÚN TIPO DE DAÑOS INDIRECTOS, ESPECIALES, EMERGENTES O PUNITIVOS QUE PUDIERAN SURGIR DEL USO, EL SERVICIO O LA INSTALACIÓN DE LOS PRODUCTOS, TANTO EN EL CASO EN QUE DICHOS DAÑOS SURGIERAN POR INCUMPLIMIENTO DE CONTRATO O POR AGRAVIO, INDEPENDIENTEMENTE DE TODA CULPA, NEGLIGENCIA O RESPONSABILIDAD ESTRICTA, O SI SEIT HA SIDO NOTIFICADO CON ANTELACIÓN SOBRE LA POSIBILIDAD DE QUE SURGIERAN DICHOS DAÑOS. CONCRETAMENTE, SEIT NO ES RESPONSABLE DE NINGÚN COSTE, COMO LUCRO CESANTE O PÉRDIDA DE INGRESOS (DIRECTOS O INDIRECTOS), PÉRDIDA DE EQUIPOS, PÉRDIDA DEL USO DE EQUIPOS, PÉRDIDA DE SOFTWARE, PÉRDIDA DE DATOS, COSTOS DE SUSTITUTOS, RECLAMACIONES DE TERCEROS O DE CUALQUIER OTRA ÍNDOLE.

NADA DE LO ESTIPULADO EN ESTA GARANTÍA LIMITADA EXCLUYE O LIMITA LA RESPONSABILIDAD DE SEIT POR MUERTE O LESIÓN PERSONAL POR SU NEGLIGENCIA, O MALA INTERPRETACIÓN FRAUDULENTO O EN LA MEDIDA QUE NO PUEDE EXCLUIRSE O LIMITARSE POR LA LEY APLICABLE.

Para reparar equipos cubiertos por la garantía se debe solicitar un número de autorización de devolución de material (RMA) al departamento de atención al cliente. Los clientes que tengan reclamaciones por garantía pueden acceder a la red mundial de servicio al cliente de SEIT a través del sitio web de Schneider Electric: www.apc.com. Elija su país en el menú desplegable de selección de países. Abra la pestaña Support (Servicio al cliente) en la parte superior de la página web para obtener información de contacto con el servicio de atención al cliente en su región. Los productos deben devolverse con los gastos de transporte prepagados y deben estar acompañados por una breve descripción del problema y prueba de la fecha y lugar de compra.

Servicio mundial de atención al cliente de Schneider Electric

Se puede obtener servicio de atención al cliente gratuito para éste y todos los demás productos de Schneider Electric de las siguientes maneras:

- Consulte el sitio web de Schneider Electric para acceder a los documentos de la Base de conocimientos de Schneider Electric y para enviar solicitudes de atención al cliente.
 - **www.apc.com** (Oficina central)
Conéctese a los sitios web de Schneider Electric adaptados para países específicos, cada uno de los cuales ofrece información de atención al cliente.
 - **www.apc.com/support/**
Servicio de atención mundial mediante la búsqueda en la base de conocimientos de Schneider Electric y mediante asistencia electrónica.
- Póngase en contacto con un Centro de atención al cliente de Schneider Electric por teléfono o correo electrónico.
 - Para obtener información de contacto de las oficinas locales específicas del país, visite **www.apc.com/support/contact**.

Póngase en contacto con el representante de Schneider Electric o con el distribuidor a quien compró el producto de Schneider Electric para recibir información sobre cómo utilizar el servicio local de atención al cliente.

Bedienungsanleitung Easy UPS On-Line SRVS-Serie 1000VA, 2000VA, 3000VA

Wichtige Sicherheitsinformationen

Lesen Sie die Anweisungen sorgfältig durch, und machen Sie sich mit dem Gerät vertraut, bevor Sie versuchen, es zu installieren, zu bedienen, zu reparieren oder zu warten. In diesem Dokument bzw. auf dem Produkt sind hin und wieder die folgenden speziellen Hinweise zu sehen, die Sie vor potenziellen Gefahren warnen oder Ihre Aufmerksamkeit auf Informationen richten sollen, die eine Vorgehensweise verdeutlichen oder vereinfachen.



Wenn zusätzlich zu einem Produktsicherheitskennzeichen mit einem Gefahren- oder Warnhinweis dieses Symbol zu sehen ist, wird auf eine elektrische Gefahr hingewiesen, die bei Nichtbeachtung der gegebenen Anweisungen zu Verletzungen führen kann.



Dies ist ein Alarmsymbol. Es warnt Sie vor potenziellen Verletzungsgefahren. Beachten Sie alle Sicherheitshinweise, die auf dieses Symbol folgen, um mögliche schwere oder tödliche Verletzungen zu verhindern.

GEFAHR

GEFAHR Zeigt eine gefährliche Situation an, die bei Nichtvermeidung zu einer tödlichen oder schweren Verletzung führt.

WARNUNG

WARNUNG Zeigt eine gefährliche Situation an, die bei Nichtvermeidung zu einer tödlichen oder schweren Verletzung führen könnte.

ACHTUNG

ACHTUNG Zeigt eine gefährliche Situation an, die bei Nichtvermeidung zu einer kleinen oder mittleren Verletzung führen könnte.

HINWEIS

HINWEIS zeigt Verfahren an, die nicht mit Verletzungen in Verbindung stehen.

Sicherheitsanweisungen und allgemeine Informationen

BEWAHREN SIE DIESE ANWEISUNGEN AUF –

Dieses Handbuch enthält wichtige Anweisungen, die bei der Installation und Wartung der USV und der Batterien befolgt werden müssen.

Überprüfen Sie den Verpackungsinhalt bei Erhalt. Informieren Sie im Schadensfall Ihren Händler und die Speditionsfirma.

- Diese USV ist ausschließlich zur Verwendung in Innenräumen vorgesehen.
- Diese USV darf beim Betrieb nicht direkter Sonneneinstrahlung oder übermäßiger Staub- bzw. Feuchtigkeitsbelastung ausgesetzt sein und darf nicht mit Flüssigkeiten in Kontakt kommen.
- Betreiben Sie die USV nicht in der Nähe offener Fenster oder Türen.
- Überzeugen Sie sich davon, dass die Lüftungsschlitze der USV nicht blockiert sind. Lassen Sie genügend Platz für eine ordnungsgemäße Belüftung.

Hinweis: Lassen Sie an allen vier Seiten der USV einen Mindestabstand von 20 cm.

- Äußere Einflüsse können Auswirkungen auf die Batterielebensdauer haben. Durch hohe Umgebungstemperaturen, schlechte Netzversorgung oder häufige Entladungen verkürzt sich die Batterielebensdauer. Befolgen Sie die Empfehlungen des Batterieherstellers.
- Schließen Sie das USV-Netzkabel direkt an eine Netzsteckdose an. Verwenden Sie keinen Überspannungsschutz und keine Verlängerungskabel.

Elektrische Sicherheit

- Um das Stromschlagrisiko beim Erden zu reduzieren, entfernen Sie die Geräte vom Wechselstromanschluss, bevor Sie sie installieren oder an andere Geräte anschließen. Schließen Sie das Netzkabel erst wieder an, nachdem alle Verbindungen hergestellt wurden.
- Der Anschluss an das Stromnetz muss durch einen qualifizierten Elektriker durchgeführt werden.
- Der Schutzerdungsleiter für die USV führt den Erdableitstrom der angeschlossenen EDV-Geräte. Ein Erdleiter ist als Teil der Stromversorgung zur und von der USV mitzuführen. Dieser Leiter muss von derselben Stärke und mit demselben Isoliermaterial versehen sein wie die geerdeten und nicht geerdeten Zuleitungen des jeweiligen Stromkreises. Hierfür ist ein grünes Kabel mit oder ohne gelben Streifen zu verwenden.
- Die Erdungsleitung ist am Wartungsgerät oder – bei Stromversorgung über einen Abzweigstromkreis – am Versorgungstransformator oder Generatormaschinensatz an die Erde anzuschließen.

Batteriesicherheit

⚠ ACHTUNG

Schwefelwasserstoffgas und übermäßiger Rauch

- Batterie muss ersetzt werden, sobald sie das Ende der Lebensdauer erreicht.
- Die Batterien müssen ersetzt werden, wenn das Gerät anzeigt, dass ein Batteriewechsel erforderlich ist.
- Ersetzen Sie Batterien immer nur durch Exemplare der gleichen Art und Anzahl, wie sie ursprünglich in der Anlage installiert waren.

Bei Nichtbeachtung dieser Vorschrift kann es zu kleinen oder mittelschweren Verletzungen und zu Schäden an der Anlage kommen.

- Batterien niemals verbrennen. Die Batterien könnten explodieren.
- Batterien niemals öffnen oder zerstören. Freigesetztes Elektrolyt kann schwere Haut- und Augenschäden verursachen und ist giftig.
- Die Wartung von Batterien sollte von Personal ausgeführt oder überwacht werden, das Kenntnisse über Batterien und die erforderlichen Vorsichtsmaßnahmen hat.
- Schneider Electric nutzt wartungsfreie versiegelte Blei-Säure-Batterien. Bei normaler Benutzung und Handhabung entsteht kein Kontakt mit internen Komponenten der Batterien. Überladung, Überhitzung und anderer Missbrauch von Batterien kann zum Auslaufen von Elektrolyt führen. Austretendes Elektrolyt ist giftig und kann zu Haut- und Augenschäden führen.
- **ACHTUNG:** Nehmen Sie vor dem Austauschen von Batterien allen leitenden Schmuck ab, z. B. Ketten, Armbanduhr und Ringe. Starker Strom durch leitende Materialien kann zu starken Verbrennungen führen.

Hochfrequenzwarnung

Dies ist ein USV-Produkt der Kategorie C2. In einem Wohnumfeld kann dieses Produkt zu Funkstörungen führen. In diesem Fall müssen ggf. weitere Gegenmaßnahmen getroffen werden.

Produktbeschreibung

Die Schneider Electric Easy UPS ist eine leistungsstarke unterbrechungsfreie Stromversorgung (USV). Die USV schützt elektronische Geräte vor Netzausfällen, Versorgungsnetz-Überlastungen, Spannungsabfällen und Spannungsschößen sowie vor kleineren Schwankungen im Stromnetz ebenso wie vor größeren Störungen. Darüber hinaus versorgt die USV angeschlossene Geräte per Akku weiterhin mit Energie; bis wieder eine normale Netzversorgung besteht oder die Akkus erschöpft sind.

Diese Bedienungsanleitung ist auf der beiliegenden Dokumentations-CD und auf der Website von Schneider Electric unter www.apc.com verfügbar.

Lieferumfang

Vor dem Installieren der USV die Sicherheitshinweise lesen.

Die Verpackung ist wiederverwertbar; bitte bewahren Sie sie zur Wiederverwendung auf oder entsorgen Sie sie sachgemäß.

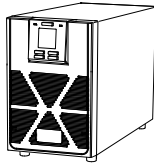

(1)
USV



(1)
Bedienungsanleitung

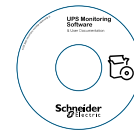

(1)
CD mit Software und
Nutzerdokumentation

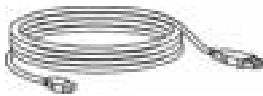

(1)
USB-Kabel



(1*)
Netzkabel



(1**)
Ausgangskabel

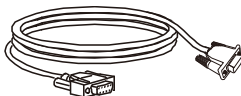

(1)
RS-232-Kabel

*: Basierend auf dem wählbaren örtlichen Eingangsstecker. **: Nur bei Modellen mit IEC-Ausgang (10 A).

HINWEIS: Modell- und Seriennummern befinden sich auf einem Etikett auf der oberen Abdeckung des Geräts.

Optionales Zubehör

Weiteres optionales Zubehör finden Sie auf den Schneider Electric-Internetseiten unter: www.apc.com.

Spezifikationen

Umgebungsspezifikationen

HINWEIS



VERMEIDEN SIE BESCHÄDIGUNGEN AN DER AUSTRÜSTUNG

- USV darf nur in Innenräumen verwendet werden.
- Der Aufstellungsort sollte robust genug sein, dem Gewicht der USV standzuhalten.
- Verwenden Sie die USV nicht in einer sehr staubigen Umgebung oder bei Temperatur- oder Feuchtigkeitsbedingungen außerhalb der angegebenen Grenzwerte.

Die Nichtbeachtung dieser Anweisungen kann zu einer Beschädigung der Ausrüstung führen.

Temperatur	Betrieb	0 ° bis 40 °C bei Nennlast. 40 bis 50 °C linear gedrosselt auf 80 % der maximalen Lastkapazität.	Diese Einheit ist ausschließlich zur Verwendung in Innenräumen vorgesehen. Wählen Sie einen Installationsort, der das Gewicht des Geräts aushält. Verwenden Sie die USV nicht in einer sehr staubigen Umgebung oder bei Temperatur- oder Feuchtigkeitsbedingungen außerhalb der angegebenen Grenzwerte. Hinweis: Laden Sie die Batteriemodule bei der Aufbewahrung alle sechs Monate auf.
	Lagerung	-20 bis 50 °C	
Höhe über NN	Betrieb	0 - 1.000 m: Normaler Betrieb 1.000 - 3.000 m: Die Last reduziert sich um 1 % je Höhenzunahme von 100 m > 3.000 m: USV funktioniert nicht	
	Lagerung	0 - 15.000 m	
Luftfeuchtigkeit		0 bis 95% relative Feuchtigkeit, nichtkondensierend	

Gewicht und Abmessungen

USV-Modell	SRVS 1000VA	SRVS 2000VA	SRVS 3000VA
Abmessungen mit Verpackung Breite x Höhe x Tiefe	235 mm (9,25") x 330 mm (12,99") x 365 mm (14,37")	235 mm (9,25") x 355 mm (13,98") x 525 mm (20,67")	325 mm (12,8") x 465 mm (18,31") x 565 mm (22,24")
Abmessungen ohne Verpackung Breite x Höhe x Tiefe	145 mm (5,7") x 223 mm (8,78") x 288 mm (11,34")	145 mm (5,7") x 238 mm (9,37") x 400 mm (15,75")	190 mm (7,5") x 336 mm (13,2") x 425 mm (16,7")
Gewicht mit Verpackung	10,6 kg	18,1 kg	29 kg
Gewicht ohne Verpackung	9,3 kg	16,8 kg	26,8 kg
Anweisungen zum Heben	< 18 kg 	18 - 32 kg 	18 - 32 kg 

Eingangs-/Ausgangsspezifikationen

USV-Modell		SRVS 1000VA	SRVS 2000VA	SRVS 3000VA
Eingang	Spannung	230 VAC, nominal		
	Frequenz	40 – 70 Hz		
	Eingangsspannungsbereich (100 % Last)	160 VAC – 280 VAC		
	Eingangsspannungsbereich (50 % Last)	110 VAC – 285 VAC		
	Eingangsleistungsfaktor (100 % ohmsche Last)	≥ 0,99 im Energiesparmodus ≥ 0,93 im Normalmodus		
	Eingangsschutz	Schutzschalter Eingang		
Ausgang	USV-Kapazität	1000 VA / 800 W	2000 VA / 1600 W	3000 VA / 2400 W
	Nennausgangsspannung	230 VAC		
	Andere programmierbare Spannung	220 VAC, 240 VAC		
	Effizienz bei Nennlast	88 % max.		
	Ausgangsspannungsregelung	± 1 % statisch		
	Ausgangsspannungsverzerrung	<ul style="list-style-type: none"> • 3 % max. bei voller linearer Last, • 6 % max. bei voller RCD-Last (100 % VA, 0,8 PF) • 15 % für die letzten 60 Sekunden der Überbrückungszeit (mit voller Last nur für interne Batterie) 		
	Frequenz bei Batteriebetrieb	50 Hz ± 0,5 % oder 60 Hz ± 0,5 %		
	Frequenz – AC-Modus	50 Hz ± 3 Hz oder 60 Hz ± 3 Hz		
	Spitzenfaktor	3:1		
	Wellenform	Sinuswelle		
	Ausgangsanschluss	Bitte beachten Sie die Merkmale an der Rückblende		
	Bypass	Interner Bypass		

Batterie

USV-Modell	SRVS 1000VA	SRVS 2000VA	SRVS 3000VA
Konfiguration	Interne Batterie		
Typ	Versiegelt, wartungsfrei (SMF) 12 V, 9 Ah		
Batteriebank-Spannung	24 V	48 V	72 V

Front-Display

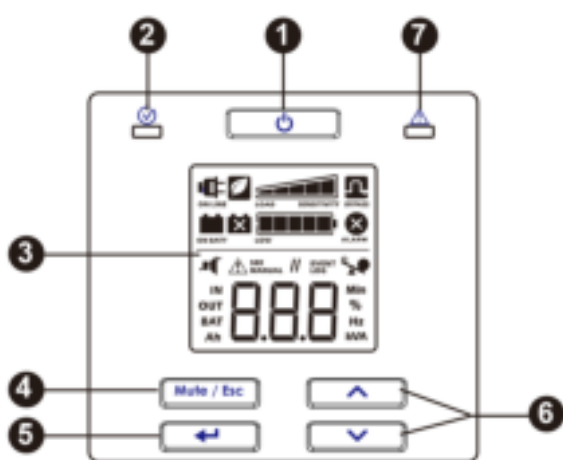

- 1 Ein-/Austaste USV
- 2 Status-LED
- 3 LC-Display
- 4 Stumm/ Esc-Taste
- 5 Eingabetaste
- 6 Aufwärts-/Abwärtstaste
- 7 Alarm-LED

Elemente auf der Rückseite

SRVS 1000VA

Modell	Ausgangstyp und -menge
SRVS1KI	 x 3

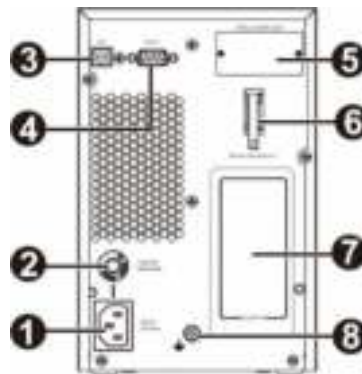

- | | |
|---------------------------------|---|
| 1 Wechselstromeingang | 5 Intelligenter Kartensteckplatz |
| 2 Schutzschalter Eingang | 6 Batterietrennstecker |
| 3 USB-Anschluss | 7 Ausgangsgruppe (siehe Ausgangstyp und -menge auf der linken Seite) |
| 4 RS-232 | 8 Erdungsschraube |

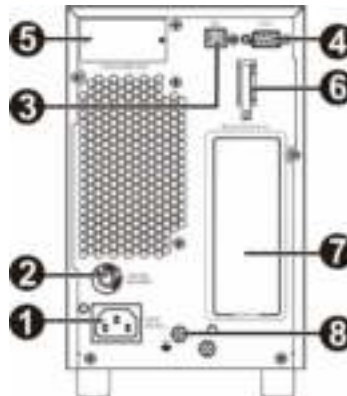

SRV 2000VA

Modell	Ausgangstyp und -menge
SRVS2KI	 x4



- | | |
|---------------------------------|---|
| 1 Wechselstromeingang | 5 Intelligenter Kartensteckplatz |
| 2 Schutzschalter Eingang | 6 Batterietrennstecker |
| 3 USB-Anschluss | 7 Ausgangsgruppe (siehe Ausgangstyp und -menge auf der linken Seite) |
| 4 RS-232 | 8 Erdungsschraube |

SRVS 3000VA

Modell	Ausgangstyp und -menge
SRVS3KI	 x6
	 x1

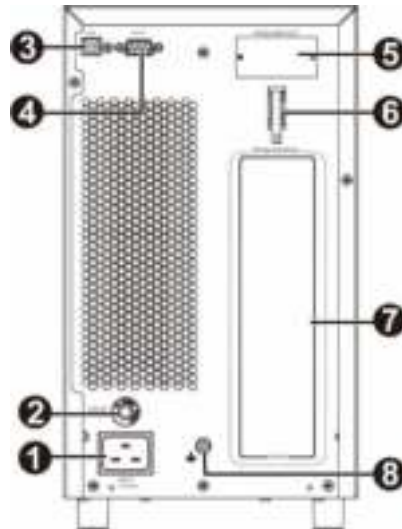

- | | | | |
|----------|------------------------|----------|--|
| 1 | Wechselstromeingang | 5 | Intelligenter Kartensteckplatz |
| 2 | Schutzschalter Eingang | 6 | Batterietrennstecker |
| 3 | USB-Anschluss | 7 | Ausgangsgruppe (siehe Ausgangstyp und -menge auf der linken Seite) |
| 4 | RS-232 | 8 | Erdungsschraube |

Basisanschlüsse

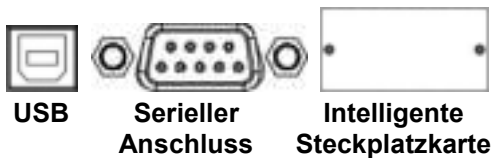

Sie können Power Management-Software und Schnittstellenkits mit der USV verwenden.
Verwenden Sie nur Schnittstellenkits, die von Schneider Electric geliefert oder empfohlen werden.

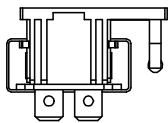

Batterietrennstecker

Diese USV ist mit einer internen Batterie ausgestattet. Bei Batterien, die bei Lieferung der USV ab Werk nicht angeschlossen sind. Vor Einschalten der USV. Bitte schließen Sie die Batterie an, indem Sie den Griff nach oben ziehen und dann in das Gerät drücken.

Einstellungen bei Inbetriebnahme

Anschließen der Batterie

Schließen Sie die Batterie an, indem Sie den Batteriegriff nach oben ziehen und dann in das Gerät drücken.

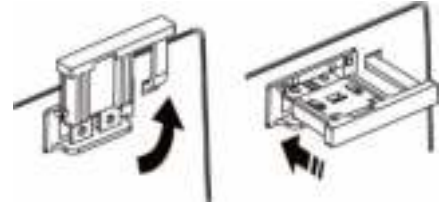

Stromkabel und Geräte an die USV anschließen

⚠ ACHTUNG

STROMSCHLAGEFAHR

- Alle Elektroarbeiten müssen von einem qualifizierten Elektriker durchgeführt werden.
- Schalten Sie die gesamte Stromversorgung am Gerät aus, bevor Sie am Gerät arbeiten. Üben Sie die Entriegelungs-/Abschaltverfahren.
- Tragen Sie bei der Arbeit mit elektrischen Betriebsmitteln keinen Schmuck.

Bei Nichtbeachtung dieser Anweisungen kann es zu kleinen oder mittleren Verletzungen kommen.



1. Schließen Sie die Geräte und die Stromversorgung an die USV an. Verwenden Sie keine Verlängerungskabel.
2. Die USV an Eingangsnetzstrom anschließen.
3. Schalten Sie den Netzbetrieb ein. Anschließend leuchtet das USV-Display auf, wenn Netzstrom verfügbar ist.

Starten der USV

Drücken Sie die Taste  an der Vorderseite der USV.



- Während der ersten fünf normalen Betriebsstunden lädt sich die Batterie auf 90 % Kapazität auf.
- Während dieser ersten Aufladung steht nicht die gesamte zu erwartende Batterielaufzeit zur Verfügung.

Kaltstart der USV

Führen Sie den angeschlossenen Geräten über die USV-Batterien mittels der Kaltstartfunktion Strom zu. Drücken Sie die Taste . Anschließend leuchtet das Display auf. Drücken Sie zur Versorgung der angeschlossenen Geräte mit Batteriestrom erneut die Taste .

Verwaltungssoftware verbinden und installieren

Easy UPS SRVS wird mit der SchneiderUPS-Verwaltungssoftware zum automatischen Herunterfahren des Betriebssystems, zur USV-Überwachung, zur USV-Steuerung und zur Betriebsberichterstattung bereitgestellt. Das folgende Diagramm ist eine Darstellung einer typischen Serverinstallation.

1. Verbinden Sie das USB-Kabel von der Rückseite der USV  mit dem geschützten Gerät, wie z. B. einem Server.
2. Bei einem Server oder einem anderen Gerät mit Betriebssystem sollten Sie die SchneiderUPS-CD einlegen und die Bildschirmanweisungen zur Einrichtung befolgen.
3. Ein integrierter serieller Anschluss  ist für weitere Kommunikationsoptionen mit einem seriellen Kabel ebenfalls verfügbar.
4. Weitere Kommunikationsoptionen sind über den integrierten intelligenten Kartensteckplatz verfügbar. Weitere Informationen finden Sie unter www.apc.com.

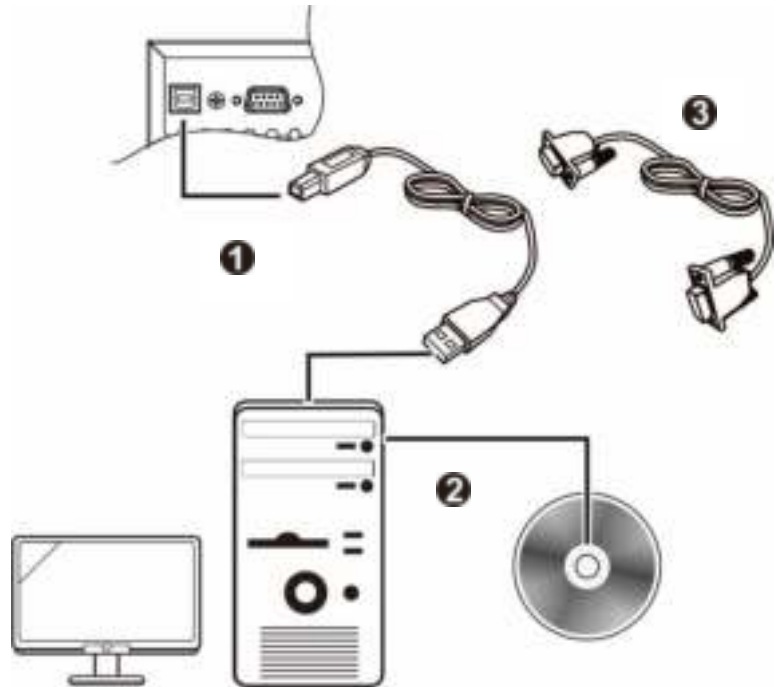









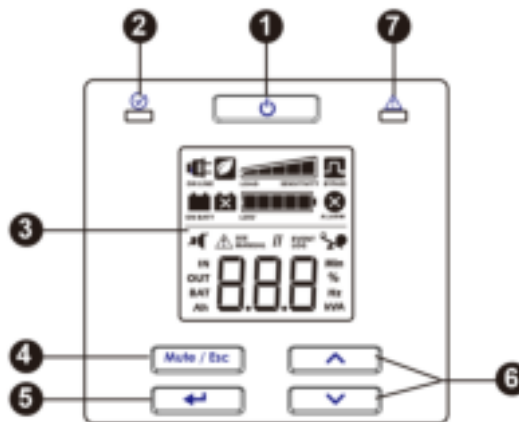

Betrieb

Arbeiten mit dem Display









Diese Easy UPS-Modelle sind mit einem intuitiven und konfigurierbaren LCD-Bildschirm ausgestattet. Dieses Display ergänzt die Softwareschnittstelle, da sie ähnliche Informationen liefern und beide zur Konfiguration der USV-Einstellungen genutzt werden können.

Das Display setzt sich aus den folgenden Tasten und Anzeigen zusammen:



1	Ein-/Austaste USV 	<ul style="list-style-type: none"> ● Drücken Sie diese Taste, um die USV einzuschalten. ● Halten Sie diese Taste zur Abschaltung der USV gedrückt, bis ein akustischer Alarm zu hören ist. ● Mit dieser Taste setzen Sie den Alarm zurück.
2	Status-LED 	<p>Die Status-LED leuchtet im eingeschalteten Zustand grün. Diese LED zeigt zwei verschiedene Zustände der Ausgabe:</p> <ul style="list-style-type: none"> ● Ausgabe aus: LED blinkt. Schalten Sie die Ausgabe mit der Ein-/Austaste ein. ● Ausgabe ein: LED leuchtet kontinuierlich grün.
3	LC-Display	Die Optionen der Anzeigeschnittstelle sind auf diesem LCD-Bildschirm sichtbar. Aktivieren Sie mit  /  das LCD, falls die Anzeige nicht leuchtet.
4	Stumm/Esc-Taste 	<ul style="list-style-type: none"> ● Zur Bestätigung des akustischen Alarms und zum vorübergehenden Deaktivieren. ● Zum Verlassen eines Untermenüs und zur Rückkehr zum Hauptmenü.
5	Eingabetaste 	Drücken Sie diese Taste zum Aufrufen des Menüs, in dem Sie während der Navigation ein Menüelement / einen Wert wählen können.
6	Aufwärts-/Abwärtstaste  	Drücken Sie diese beiden Tasten zum Umschalten zwischen Hauptmenüoptionen und Anzeigebildschirmen.
7	Alarm-LED 	Diese Alarm-LED leuchtet rot, wenn die USV einen Fehler erkennt. Bei USV-Benachrichtigungen blinkt sie rot. Beachten Sie „Alarmer und Benachrichtigungen“ auf Seite 11 in dieser Anleitung.

Symbole am LC-Display

 ON LINE	Netzspannungsbetrieb: Die USV zieht Netzstrom und versorgt die angeschlossenen Geräte als Doppelwandler mit Strom.
 ON BATT	Batteriebetrieb: Die USV versorgt angeschlossene Geräte mit Batteriestrom.
	Batterie ersetzen: Die Batterie ist nicht sicher verbunden oder nähert sich dem Ende ihrer Einsatzzeit und sollte ausgetauscht werden.
 BYPASS	Bypass: Die USV arbeitet im Bypass-Betrieb und leitet den Netzstrom direkt an die angeschlossenen Geräte. Bei einem internen Ereignis oder einer Überlastung schaltet sich die USV in den Bypass-Betrieb. In diesem Modus ist kein Batteriebetrieb möglich. Beachten Sie „Alarmer und Benachrichtigungen“ auf Seite 11 in dieser Anleitung. Dieses Symbol in Kombination mit dem Energiesparmodus-Symbol zeigt an, dass sich die USV im Energiesparmodus befindet.
 ALARM	Systemalarmer: Ein interner Fehler wurde erkannt. Beachten Sie „Alarmer und Benachrichtigungen“ auf Seite 11 in dieser Anleitung.
	Überlast: Die an die USV angeschlossenen Geräte verbrauchen mehr Leistung als die USV zur Verfügung stellen kann.
 LOW	Batterieladung: Die Batterieladung wird durch die Anzahl der leuchtenden Balken in der Leiste angezeigt. Wenn alle fünf Balken leuchten, ist der Akku vollständig geladen. Jeder Balken steht für etwa 20 % der Batteriekapazität.
 LOAD SENSITIVITY	Lastpegel: Die Auslastung (in Prozent) wird durch die Anzahl der leuchtenden Balken in der Last-Leiste angezeigt. Jeder Balken steht für etwa 20 % der maximalen Lastkapazität.
	Stumm: Das durchgestrichene Symbol zeigt an, dass der akustische Alarm abgeschaltet ist.



Energiesparmodus: Ein leuchtendes Symbol zeigt an, dass das Gerät im Energiesparmodus arbeitet. Die angeschlossenen Geräte empfangen den Netzstrom direkt, solange Eingangsspannung und Frequenz innerhalb der konfigurierten Grenzwerte liegen.



Alarm oder Benachrichtigung: Die USV hat einen Fehler erkannt oder die USV befindet sich im Konfigurationsmodus. Beachten Sie „Alarmer und Benachrichtigungen“ auf Seite 11 in dieser Anleitung.

EVENT LOG



Ereignis: Das Symbol leuchtet, wenn der Nutzer das Ereignisprotokoll ein sieht.

Alarmer und Systemfehler

Statusanzeigen

Kontinuierliche Signaltöne, jede halbe Sekunde	Geringer Batteriestand - Die Batterie ist fast vollständig entladen. Die USV schaltet sich in Kürze aus.
4 kurze akustische Signale alle 30 s (erstes akustisches Signal beginnt nach 4 s im Batteriebetrieb)	Überlastung - Die an die USV angeschlossenen Geräte verbrauchen mehr Leistung als angegeben.
Kontinuierliches akustisches Signal aktiviert	Batteriebetrieb - Die USV versorgt angeschlossene Geräte mit Batteriestrom.
Kurze Folge akustischer Signale alle 2,5 s	Alarmzustand - Die USV hat einen Fehler erkannt. Beachten Sie „Alarmer und Benachrichtigungen“ in dieser Anleitung.
Es wird alle 5 Stunden 1 Minute lang jede halbe Sekunde ein kurzes akustisches Signal ausgegeben.	Batterie nicht angeschlossen. Fehlerhafte Batterie (auswechseln)
Zwei kurze akustische Signale alle 5 s	Ereignis Bypass-Zustand - Die USV hat einen Fehler erkannt. Angeschlossene Geräte werden über das Bypass-Relais mit Strom versorgt.

Alarmer

Anzeige code	Beschreibung	Lösung
SC	Es ist ein Kurzschluss am Ausgang der USV aufgetreten. Das Gerät versucht, diesen Zustand automatisch zu beheben.	Prüfen Sie, ob der USV-Ausgang kurzgeschlossen ist. Beheben Sie den Kurzschluss und warten Sie, bis sich das Gerät automatisch wieder zurückgesetzt hat, oder drücken Sie zum Starten der USV die Taste  . Hinweis: Die Stromversorgung der angeschlossenen Geräte wird unterbrochen, wenn sich die USV in diesem Zustand befindet.
OL	Es ist eine Überlastung der USV aufgetreten.	Trennen Sie einige nicht benötigte Geräte von der USV, um die Überlastung zu beenden.
dCH	Die USV hat einen Gleichspannungsfehler erkannt. Das Gerät versucht, diesen Zustand automatisch zu beheben.	Falls die USV den Zustand nicht automatisch beheben kann, wenden Sie sich bitte an Schneider Electric.
Hot	Die Temperatur des Gerätes hat die eingestellten Grenzwerte überschritten.	Um die Belastung der USV zu reduzieren, nicht benötigte Geräte von der USV trennen. Stellen Sie sicher, dass sich die Umgebungstemperatur innerhalb der Grenzwerte befindet. Vergewissern Sie sich darauf, dass ein angemessener Freiraum eingehalten wird.
CH9	Die USV hat einen Fehler des Lade gerätes erkannt.	Prüfen Sie, ob der USV-Batterieanschluss kurzgeschlossen ist. Drücken Sie zum Starten der USV die Taste  .

Wenden Sie sich bei allen anderen Alarmcodes an Schneider Electric.

Benachrichtigungen

Anzeigecode	Beschreibung	Lösung
bdc	Batterie ist nicht angeschlossen.	Schließen Sie die Batterie an die USV an. Beachten Sie „Startvorgang“ auf Seite 8 in dieser Anleitung.

USV-Anzeigeparameter

Die am Bildschirm angezeigten Betriebsdaten sind in der Tabelle aufgeführt.















Navigieren Sie mit der Taste  / .

Parameter	Einheiten	Anzeigesymbole
Ausgangsspannung	VAC	OUT, V
Ausgangsfrequenz	Hz	OUT, Hz
Eingangsspannung	VAC	IN, V
Eingangsfrequenz	Hz	IN, Hz
Batteriespannung	VDC	BAT, V
Umgebungstemperatur	°C	Wert, C
Status der Batterieladung	%	BAT, %
Last in Prozent (maximale Wattzahl oder VA)	%	OUT, %
Last in kVA	kVA	OUT, kVA
Gesamte Ah-Kapazität der angeschlossenen Batterie	Ah	BAT, Ah
Verbleibende Laufzeit im Batteriebetrieb	Minuten	BAT, Min

Konfiguration

USV-Parameter konfigurieren

Führen Sie folgende Schritte zur Konfiguration der Parameter in der USV durch:



1. Drücken Sie die Taste .
2. Navigieren Sie mit  /  zu „Set“.
3. Drücken Sie die Taste .
4. Navigieren Sie mit  /  durch die Parameter.
5. Drücken Sie zum Bearbeiten eines Parameters die Taste . Symbole zeigen durch Blinken an, dass sie bearbeitet werden.
6. Navigieren Sie mit  /  durch die für den ausgewählten Parameter verfügbaren Optionen.
7. Wählen Sie mit  eine Option oder drücken Sie zum Abbrechen der Bearbeitung des aktuellen Parameters die Taste . Anschließend hören die Symbole auf zu blinken.
8. Navigieren Sie mit  /  durch die Parameter.
9. Drücken Sie zum Beenden der Menünavigation die Taste .















USV-Einstellungen

Konfigurieren Sie die USV-Einstellungen über die Anzeigeschnittstelle. Beachten Sie zum Bearbeiten der Parameter den Abschnitt „USV-Parameter konfigurieren“.

Funktion	Werkseinstellung	Benutzeroptionen	Beschreibung
Ausgangsspannung	230 VAC	220, 230, 240 VAC	Ermöglicht die Einstellung der Ausgangsspannung, während sich die USV im Netzmodus befindet.
Akustischer Alarm	Aktivieren	Aktivieren, Deaktivieren	Die USV lässt den akustischen Alarm verstummen, wenn sie auf Deaktivieren eingestellt oder die MUTE-Taste am Bildschirm gedrückt wird.
Energiesparmodus / Hocheffizienzmodus	Deaktiviert	Aktivieren/Deaktivieren	Wenn dieser Modus aktiviert ist, empfangen angeschlossene Geräte Netzstrom über das Bypass-Relais, solange die Eingangsspannung innerhalb des Bereichs von $\pm 5\%$ der konfigurierten Ausgangsspannung und ± 3 Hz der konfigurierten Ausgangsfrequenz liegt. In diesem Modus wird der Wechselrichter ausgeschaltet. Falls die Netzeinspeisung den Bereich verlässt, wird der Wechselrichter eingeschaltet. Die Last wechselt in den Netz- oder Akkumodus. Die Stromversorgung der angeschlossenen Geräte könnte bis zu 10 Millisekunden unterbrochen werden.
Mindestbatteriekapazität zum Neustart einstellen	0%	0%, 15%, 50%, 90%	Der USV-Ausgang wird nicht eingeschaltet, bis die Batterie einen Ladestand erreicht hat, der zur Bereitstellung der durch diese Einstellung konfigurierten Laufzeit ausreicht. Bei Einstellung auf 0% wird die Der USV-Ausgang sofort nach Wiederherstellung der Netzstromversorgung eingeschaltet.
Statusanzeige eines niedrigen Batteriestands einstellen	2 min	2 min, 5 min, 7 min, 10 min	Die USV gibt einen akustischen Alarm aus, sobald die tatsächliche Laufzeit das vom Endanwender eingestellte Limit erreicht. Der akustische Alarm wird nur ausgegeben, wenn die USV im Batteriemodus läuft.

Erweiterte Anzeigenavigation

Es gibt fünf Optionen im Hauptmenü und zwei Untermenüoptionen in der USV-Anzeige. Drücken Sie am Startbildschirm zum Aufrufen dieser Menüoptionen die Taste . Navigieren Sie mit  /  zwischen den Menüoptionen.

Menüoption	Beschreibung								
SET	<p>Konfigurieren der USV Über diese Menüoption können Sie die USV-Parameter konfigurieren. Drücken Sie zum Einsehen der Konfigurationsoptionen die Taste . Einzelheiten finden Sie unter „USV-Parameter konfigurieren“ auf Seite 13. Drücken Sie zum Zurückkehren zum Startbildschirm die Taste .</p>								
LOG	<p>Ereignisprotokoll anzeigen Über diese Menüoption können Sie das USV-Ereignisprotokoll einsehen. Die USV zeichnet die letzten 10 Ereignisse auf und zeigt die Codes in diesem Protokoll an. Drücken Sie zum Einsehen des Protokolls die Taste . Blättern Sie mit  /  durch die protokollierten Ereignisse. Mit der Taste  rufen Sie ältere Ereignisse auf, mit der Taste  rufen Sie neuere Ereignisse auf. Jeder Protokolleintrag hat einen numerischen und textbasierten Ereigniscode. Am Ende des Protokolls wird das Wort „Ende“ angezeigt. Drücken Sie zum Zurückkehren zum Startbildschirm die Taste .</p>								
UPS	<p>USV-Informationen anzeigen Über diese Menüoption können Sie das USV-Informationen einsehen. Drücken Sie zum Einsehen der Nennangaben der USV die Taste . Drücken Sie zum Einsehen der USV-Firmware-Version die Taste . Drücken Sie zum Zurückkehren zum Startbildschirm die Taste .</p>								
bYP	<p>Nutzerbefehl zum Umschalten in den Bypass-Modus Mit dieser Menüoption können Sie die USV in den Bypass-Modus versetzen oder vom Bypass-Modus in den Netzmodus wechseln. Drücken Sie die Taste : Put: Zum Umschalten der USV in den Bypass-Modus. Hinweis: Die Energiezufuhr zu den angeschlossenen Geräten wird unterbrochen, falls sich die Netzspannung nicht innerhalb der Grenzwerte bewegt Out: Beenden Sie den Bypass-Modus der USV und stellen Sie eine saubere Stromversorgung der angeschlossenen Geräte wieder her.</p>								
tSt	<p>Batterie-Selbsttest ausführen Führen Sie anhand dieser Menüoption einen Selbsttest durch und ermitteln Sie den Batteriestatus. Drücken Sie zum Starten des Tests die Taste . Falls der Testbefehl akzeptiert wird, startet die USV einen Selbsttest und zeigt einen Countdown am Display. Nach Ablauf des Tests werden Meldungen angezeigt.</p> <table> <tr> <td>rFd</td> <td>Test verweigert. Die Ausgabe ist abgeschaltet oder die Batterie ist nicht aufgeladen.</td> </tr> <tr> <td>Fl d</td> <td>Test nicht bestanden</td> </tr> <tr> <td>PRs</td> <td>Test bestanden</td> </tr> <tr> <td>Abt</td> <td>Test aufgrund interner Ursachen abgebrochen</td> </tr> </table> <p>Drücken Sie zum Zurückkehren zum Startbildschirm die Taste .</p>	rFd	Test verweigert. Die Ausgabe ist abgeschaltet oder die Batterie ist nicht aufgeladen.	Fl d	Test nicht bestanden	PRs	Test bestanden	Abt	Test aufgrund interner Ursachen abgebrochen
rFd	Test verweigert. Die Ausgabe ist abgeschaltet oder die Batterie ist nicht aufgeladen.								
Fl d	Test nicht bestanden								
PRs	Test bestanden								
Abt	Test aufgrund interner Ursachen abgebrochen								

Fehlerbehebung

Verwenden Sie die folgende Tabelle, um kleinere Installations- und Betriebsprobleme selbst zu lösen. Bei komplizierteren Installationsproblemen sehen Sie bitte auf der Website von Schneider Electric unter www.apc.com nach.

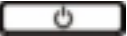
Problem und/oder mögliche Ursachen	Lösung
Die USV lässt sich trotz vorhandener Netzeinspeisung nicht einschalten oder gibt keinen Strom ab	
Die USV ist nicht eingeschaltet.	Drücken Sie die  -Taste, um die USV einzuschalten.
Die USV ist nicht an das Stromnetz angeschlossen.	Vergewissern Sie sich, dass das Netzkabel zwischen USV und Stromversorgung auf beiden Seiten richtig angeschlossen ist. Beachten Sie „Startvorgang“ auf Seite 8 in dieser Anleitung.
Der Eingangs-Schutzschalter der USV hat ausgelöst.	Drücken Sie die Reset-Taste des Eingangs-Schutzschalter an der Rückblende.
Die USV läuft im Batteriebetrieb, obwohl sie an eine Spannungsversorgung angeschlossen ist.	
Die Netzspannung oder –frequenz ist hoch, niedrig oder schwankt.	Schließen Sie die USV an eine andere Steckdose in einem anderen Stromkreis an. Prüfen Sie die Netzeingangsspannung, um sicherzustellen, dass die Einheit mit Spannung versorgt wird. Falls das Display eingeschaltet ist, prüfen Sie Eingangsspannung und Frequenz.
USV versorgt bei angeschlossener Batterie die angeschlossenen Geräte nicht mit Strom	
Die USV ist nicht eingeschaltet.	Falls die USV ausgeschaltet ist (das Display ist nicht eingeschaltet), befolgen Sie die Schritte unter „Kaltstart der USV“ auf Seite 8.
Die Batterie ist nicht angeschlossen.	Schließen Sie die Batterie an die USV an. Beachten Sie „Startvorgang“ auf Seite 8 in dieser Anleitung.
Trennung wegen geringen Batteriestands. Möglicherweise hat die USV die Batterie aufgrund eines Stromausfalls entladen und die Ausgabe aufgrund eines niedrigen Batteriestands ausgeschaltet.	Warten Sie, bis die Netzstromversorgung wiederhergestellt und die Batterie aufgeladen ist. Schalten Sie die Stromausgabe nach Wiederherstellung der Netzstromversorgung ein, indem Sie die Taste  drücken.
Die USV gibt in großen Intervallen ein akustisches Signal ab.	
Die USV läuft im Batteriebetrieb normal.	Die USV hat einen Fehler erkannt. Beachten Sie „Alarmer und Benachrichtigungen“ auf Seite 11 in dieser Anleitung.
Die Alarm-LED leuchtet Die USV zeigt eine Alarmmeldung an und gibt ein konstantes akustisches Signal von sich.	
Die USV hat einen Fehler erkannt.	Beachten Sie „Alarmer und Benachrichtigungen“ auf Seite 11 in dieser Anleitung.
Kein akustischer Alarm von der USV, selbst wenn die Alarm-LED leuchtet.	
Akustischer Alarm ist deaktiviert.	Ändern Sie die USV-Konfiguration zur Aktivierung des akustischen Alarms.
USV liefert nicht die erwartete Überbrückungszeit.	
Die USV-Batterie ist aufgrund eines kürzlichen Stromausfalls entladen.	Nach längerem Stromausfall müssen die Batterien wieder aufgeladen werden. Die Batterien verschleifen schneller, wenn sie ohne komplette Aufladung wieder in Anspruch genommen oder bei höheren Temperaturen eingesetzt werden.
Die Batterie hat fast das Ende ihrer Lebensdauer erreicht.	Wenn die Batterie ihre maximale Lebensdauer fast erreicht hat, sollten Sie sie austauschen, auch wenn die Anzeige „Batterie ersetzen“ noch nicht leuchtet. Beachten Sie „Startvorgang“ auf Seite 8 in dieser Anleitung.

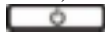
Problem und/oder mögliche Ursachen	Lösung
Die USV schaltet nicht ab	
Die Taste POWER OFF wurde nicht richtig gedrückt	Halten Sie die Taste  zur Abschaltung der USV gedrückt, bis der akustische Alarm zu hören ist.
Netzeingangsstrom liegt an.	Die interne Steuerung der USV kann nicht abgeschaltet werden solange Netzstrom anliegt. Schalten Sie die USV ab, indem Sie die Netzstromversorgung entfernen und die Taste  drücken. Lassen Sie die Taste bei Ertönen des akustischen Alarms los.
USV ist im Bypass-Modus und die LED-Leuchtet nicht rot.	
USV ist im Energiesparmodus.	Deaktivieren Sie bei Bedarf den Energiesparmodus.
USV ist so konfiguriert, dass sie im Bypass-Modus bleibt.	Ändern Sie die Konfiguration zum Beenden des Bypass-Modus.
USV bleibt selbst nach Aufhebung des Temperaturalarms im Bypass-Modus.	Verringern Sie die verbundene Last auf < 90 %, um die USV in den Online-Modus zu versetzen.
Die USV wurde überlastet und ist in den Bypass-Modus gewechselt.	<p>Die angeschlossenen Geräte überschreiten die maximale Last (technische Daten hierzu finden Sie auf der Website von Schneider Electric www.apc.com.)</p> <p>Der akustische Alarm ertönt so lange, wie die Überlast besteht. Trennen Sie einige nicht benötigte Geräte von der USV, um die Überlastung zu beenden.</p> <p>Die USV versorgt die Geräte weiterhin mit Strom, so lange sie im Bypass-Modus ist und der Überlastschalter nicht ausgelöst wird. Bei Unterbrechung der Netzstromversorgung liefert die USV jedoch keinen Batteriestrom.</p>
Die USV erkannte einen Fehler und wechselte in den Bypass-Modus.	Beachten Sie „Alarmer und Benachrichtigungen“ auf Seite 11 in dieser Anleitung.

Transport

1. Alle angeschlossenen Geräte müssen abgeschaltet und getrennt werden.
2. Trennen Sie das Gerät von der Stromversorgung.
3. Trennen Sie alle internen und externen Batterien (falls vorhanden).
4. Folgen Sie den Versandanweisungen unter *Service* in diesem Handbuch.

Service

Falls die Einheit einmal instandgesetzt werden muss, senden Sie sie bitte nicht an den Händler ein.

Befolgen Sie diese Schritte:

1. Lesen Sie im Handbuch die Erklärungen im Kapitel *Problemlösung*, um gelegentlich auftretende Probleme allgemeiner Natur selbst beheben zu können.
2. Wenn das Problem weiterhin besteht, wenden Sie sich bitte über die Website von Schneider Electric unter **www.apc.com** an unseren Kundendienst.
 - a › Notieren Sie die Modell- und Seriennummer sowie das Kaufdatum. Die Modell- und die Seriennummern befinden sich auf der Rückseite des Geräts und können bei einigen Modellen LC-Display angezeigt werden.
 - b › Wenden Sie sich an den Kundendienst. Ein Techniker wird versuchen, das Problem telefonisch zu klären. Ist dies nicht möglich, wird der Techniker Ihnen eine Warenrücknahmenummer (RMA-Nr.) zuweisen.
 - c › Wenn die Garantie noch besteht, wird die Reparatur kostenlos durchgeführt.
 - d › Die Service-Verfahren und Rücksendebestimmungen können von Land zu Land unterschiedlich sein. Bitte informieren Sie sich auf der Schneider Electric-Website **www.apc.com** über den für Ihr Land vorgesehenen Ablauf.
3. Verpacken Sie die Einheit sorgfältig, um Transportschäden zu vermeiden. Verwenden Sie keine Styroporchips als Verpackungshilfsmittel.
Transportschäden sind nicht von der Garantie abgedeckt.
Hinweis: Vor dem Transport immer Batteriemodule in einer USV oder externen Batterie-Einheit trennen. Die getrennten internen Batterien können in der USV oder Batterie-Einheit verbleiben.
4. Vermerken Sie die RMA-Nr., die Sie vom Kundendienst erhalten haben, auf der Verpackung.
5. Senden Sie die Einheit als versichertes und freigemachtes Paket an die Adresse, die Sie vom Kundendienst erhalten haben.

Beschränkte Werksgarantie

Schneider Electric IT Corporation (SEIT) gewährleistet, dass dieses Produkt für die Dauer von zwei (2) Jahren ab Kaufdatum frei von Material- und Verarbeitungsfehlern ist. Die Verpflichtung von SEIT gemäß dieser Garantie ist auf die Reparatur oder den Ersatz (Entscheidung trifft SEIT) jeglicher defekter Produkte begrenzt. Die Reparatur oder der Austausch eines fehlerhaften Produkts oder Teils verlängert nicht den ursprünglichen Garantiezeitraum.

Die Produktregistrierung kann online unter warranty.apc.com vorgenommen werden.

SEIT haftet nicht gemäß der Garantie, wenn hauseigene Prüfungen und Untersuchungen ergeben haben, dass der vermeintliche Produktschaden nicht existiert beziehungsweise durch Missbrauch, Fahrlässigkeit, unsachgemäße Installation oder Prüfungen von Endverbrauchern oder Dritten bzw. durch eine Verwendung entgegen den Empfehlungen oder Spezifikationen von SEIT verursacht wurde. Darüber hinaus haftet SEIT nicht für Schäden infolge von: 1) nicht autorisierten Reparatur- oder Umbauversuchen an dem Produkt, 2) falschen oder inadäquaten elektrischen Spannungen oder Verbindungen, 3) nicht vorschriftsmäßigen Betriebsbedingungen vor Ort, 4) höherer Gewalt, 5) ungenügendem Schutz vor Witterungseinflüssen oder 6) Diebstahl. Keinesfalls haftet SEIT im Rahmen dieser Garantie für Produkte, bei denen die Seriennummer verändert, unkenntlich gemacht oder entfernt wurde.

ES BESTEHEN ÜBER DIE VORSTEHEND GENANNTEN BESTIMMUNGEN HINAUS KEINE ANDEREN GARANTIE AUSDRÜCKLICHER, STILLSCHWEIGENDER, GESETZLICHER ODER SONSTIGER NATUR FÜR IRGENDWELCHE PRODUKTE, DIE AUFGRUND ODER IN VERBINDUNG MIT DIESER VEREINBARUNG VERKAUFT, GEWARTET ODER BEREITGESTELLT WURDEN.

SEIT LEHNT ALLE STILLSCHWEIGENDEN GARANTIE HINSICHTLICH DER MARKTGÄNGIGKEIT UND EIGNUNG FÜR EINEN BESTIMMTEN ZWECK AB.

AUSDRÜCKLICHE GARANTIE VON SEIT KÖNNEN IM ZUSAMMENHANG MIT DER ERTEILUNG VON TECHNISCHEM ODER ANDEREN RATSCHLÄGEN ODER DIENSTLEISTUNGEN DURCH SEIT BEZÜGLICH DER PRODUKTE NICHT ERWEITERT, VERRINGERT ODER BEEINTRÄCHTIGT WERDEN. WEITERHIN ENTSTEHEN DIESBEZÜGLICH KEINE AUFLAGEN ODER LEISTUNGSVERPFLICHTUNGEN.

DIE OBEN BESCHRIEBENEN GARANTIE UND GEWÄHRLEISTUNGSANSPRÜCHE SIND EXKLUSIV UND GELTEN ANSTELLE ALLER ANDEREN GARANTIE UND GEWÄHRLEISTUNGSANSPRÜCHE. DIE OBEN GENANNTEN GARANTIE BEGRÜNDEN DIE EINZIGE LEISTUNGSVERPFLICHTUNG VON SEIT UND STELLEN IHRE EINZIGEN RECHTSMITTEL IM FALLE VON GARANTIEVERLETZUNGEN DAR. DIE GARANTIE VON SEIT GELTEN NUR FÜR DEN URSPRÜNGLICHEN KÄUFER UND KÖNNEN NICHT AUF DRITTE ÜBERTRAGEN WERDEN.

IN KEINEM FALL HAFTEN SEIT, SEINE VERANTWORTLICHEN, DIREKTOREN, TOCHTERUNTERNEHMEN ODER ANGESTELLTEN FÜR IRGENDWELCHE INDIREKTEN, SPEZIELLEN, IN DER FOLGE ENTSTANDENEN ODER STRAFRECHTLICH RELEVANTEN SCHÄDEN, DIE AUS DER VERWENDUNG, WARTUNG ODER INSTALLATION DER PRODUKTE ENTSTEHEN. DIES GILT UNABHÄNGIG DAVON, OB SOLCHE SCHÄDEN AUS EINEM VERTRAG ODER AUS UNERLAUBTER HANDLUNG RESULTIEREN, OB MIT ODER OHNE VERSCHULDEN, FAHRLÄSSIGKEIT ODER KAUSALHAFTUNG, UND ZWAR AUCH DANN NICHT, WENN SEIT ZUVOR AUF DIE MÖGLICHKEIT SOLCHER SCHÄDEN AUFMERKSAM GEMACHT WURDE. SEIT HAFTET INSBESONDERE NICHT FÜR ENTSTANDENE KOSTEN IRGENDWELCHER ART, Z. B. ENTGANGENE GEWINNE ODER EINKÜNFTE (OB AUF DIREKTEM ODER INDIREKTEM WEGE), VERLUST VON GERÄTEN, VERLUST DER NUTZUNGSMÖGLICHKEIT EINES GERÄTS, VERLUST VON SOFTWARE ODER DATEN, ERSATZKOSTEN, ANSPRÜCHE DRITTER ODER ANDERE KOSTEN.

NICHTS IN DIESER EINGESCHRÄNKTE GARANTIE IST DAHINGEHEND AUSZULEGEN, DASS SEIT EINEN AUSSCHLUSS ODER EINE EINSCHRÄNKUNG SEINER HAFTUNG BEI TOD ODER VERLETZUNG INFOLGE SEINER EIGENEN FAHRLÄSSIGKEIT ODER ARGLISTIGER FALSCHDARSTELLUNG ANSTREBT – IN DEM MASS, IN DEM DIES NACH GELTENDEM RECHT NICHT AUSGESCHLOSSEN ODER EINGESCHRÄNKT WERDEN KANN.

Bevor unter die Garantie fallende Reparaturleistungen in Anspruch genommen werden können, muss beim Kundendienst eine Warenrücknahmenummer (Returned Material Authorization; RMA) angefordert werden. Garantieansprüche können im weltweiten Kundendienst-Netzwerk von SEIT über die Supportseiten auf der Website von Schneider Electric unter: www.apc.com. Wählen Sie aus dem Dropdown-Menü das entsprechende Land aus. Öffnen Sie die Registerkarte „Support“ oben auf der Webseite, um Kontaktinformationen für den Kundendienst in Ihrer Region zu erhalten. Produkte müssen als vom Absender bezahlte Sendung zurückgeschickt werden und eine kurze Beschreibung des aufgetretenen Problems sowie einen Nachweis von Ort und Datum des Kaufs enthalten.

Schneider Electric – weltweiter Kundendienst

Schneider Electric bietet für dieses und für andere Produkte kostenlosen Kundendienst. Dazu bestehen folgende Möglichkeiten:

- Über die Website von Schneider Electric – hier finden Sie entsprechende Dokumente in der Schneider Electric-Knowledgebase und können Anfragen einreichen.
 - **www.apc.com** (Unternehmenszentrale)
Auf der lokalisierten Schneider Electric-Website des gewünschten Landes können Sie Informationen zur Kundenunterstützung in der entsprechenden Sprache abrufen.
 - **www.apc.com/support/**
Weltweiter Kundendienst über Abfragen der Schneider Electric Knowledge Base sowie mittels e-Support.
- Sie können ein Kundendienstzentrum von Schneider Electric telefonisch oder per E-Mail kontaktieren.
 - Lokale, länderspezifische Kundendienstzentren: Kontaktinformationen finden Sie unter **www.apc.com/support/contact**.

Informationen dazu, wie Sie den lokalen Kundendienst kontaktieren können, erhalten Sie von dem Schneider Electric-Repräsentanten oder Fachhändler, bei dem Sie das Schneider Electric-Produkt erworben haben.

Kullanım Kılavuzu Easy UPS Hatta Bağlı SRVS Serisi 1000VA, 2000VA, 3000VA

Önemli Güvenlik Bilgileri

Talimatları dikkatli bir şekilde okuyun ve kurmaya, çalıştırmaya, servis veya bakım uygulamaya çalışmadan önce cihazı tanımak için ekipmanı inceleyin. Olası tehlikeler hakkında uyarı sağlamak veya bir prosedürü açıklığa kavuşturan ya da basitleştiren bilgiye dikkat çekmek için bu kılavuzda veya donanımın üzerinde aşağıdaki özel mesajlar görülebilir.



Bu sembolün Tehlike veya Uyarı ürün güvenlik etiketine eklenmesi, talimatların uygulanmaması durumunda kişisel yaralanmaya neden olabilecek elektrik tehlikesinin olduğunu belirtir.



Bu güvenlik uyarısı sembolüdür. Sizi olası kişisel yaralanma tehlikeleri konusunda uyarmak için kullanılır. Olası yaralanmalardan veya ölümden kaçınmak için bu sembolü takip eden tüm güvenlik mesajlarına uyun.

▲ TEHLİKE

TEHLİKE bildirimi, önlenmemesi durumunda ölümlü veya ciddi yaralanmayla sonuçlanacak tehlikeli bir durumu belirtir.

▲ UYARI

UYARI bildirimi, önlenmemesi durumunda ölümlü veya ciddi yaralanmayla sonuçlanabilecek tehlikeli bir durumu belirtir.

▲ İKAZ

İKAZ bildirimi, önlenmemesi durumunda hafif veya orta derecede yaralanmayla sonuçlanabilecek tehlikeli bir durumu belirtir.

BİLGİ

BİLGİ bildirimi, fiziksel yaralanmayla ilgili olmayan uygulamaları belirtmek için kullanılır.

Güvenlik ve Genel Bilgi

BU TALİMATLARI SAKLAYIN –

Bu kılavuz, UPS'nin ve akülerin montajı ve bakımı sırasında uyulması gereken önemli talimatlar içermektedir. Elinize geçtiğinde paketin içindekileri inceleyin. Herhangi bir hasar varsa nakliye firmasına ve bayinize bildirin.

- Bu UPS yalnızca kapalı alanda kullanım içindir.
 - Bu UPS'yi doğrudan güneş ışığında, sıvılara temas edecek şekilde veya aşırı toz ya da nem bulunan yerlerde çalıştırmayın.
 - UPS'yi açık pencerelerin veya kapıların yakınında çalıştırmayın.
 - UPS'teki hava deliklerinin tıkanmış olmadığından emin olun. Doğru havalandırma için yeterli boşluk bırakın.
- Not:** UPS'nin dört tarafında da en az 20 cm boşluk bırakın.

- Çevresel faktörler akü ömrünü etkilemektedir. Yüksek ortam sıcaklıkları, düşük kaliteli şebeke gücü ve akımın sık sık boşalması akü ömrünü kısaltacaktır. Akünün üreticisinin önerilerine uyun.
- UPS güç kablosunu doğrudan bir duvar prizine takın. Aşırı gerilim koruyucusu veya ara kablo kullanmayın.

Elektriksel Güvenlik

- Topraklamayı tespit edemediğiniz zaman, ekipmanı monte etmeden veya diğer teçhizata bağlamadan ekipmanın şebeke elektrigiyle olan bağlantısını kesin. Güç kablosunu bütün bağlantılar yapıldıktan sonra takın.
- Elektrik (şebeke) bağlantısı uzman bir elektrikçi tarafından yapılmalıdır.
- UPS için koruyucu toprak iletken yük cihazlarından (bilgisayar cihazları) gelen sızıntı akımını taşır. UPS'ye enerji sağlayan şebeke devresine izole bir topraklama iletkeni bağlanmalıdır. İletken, topraklı ve topraksız şebeke devresi besleme iletkenleriyle aynı boyuta ve aynı izolasyon malzemesine sahip olmalıdır. İletken kablosu yeşildir, üzerinde sarı çizgiler de olabilir.
- Topraklama iletkeni servis ekipmanında, ayrı bir sistemden besleniyorsa besleme transformatörüne veya motor-jeneratör setine topraklanmalıdır.

Akü Güvenliği

⚠ İKAZ
<p>HİDROJEN SÜLFÜR GAZI VE AŞIRI DUMAN</p> <ul style="list-style-type: none">• Aküler, hizmet ömürlerinin sonuna geldiklerinde değiştirilmelidir.• Ünite akü değişiminin gerekli olduğunu belirttiğinde aküler değiştirilmelidir.• Aküleri, üniteye orijinal olarak bulunanlarla aynı sayıda ve tipte akülerle değiştirin. <p>Bu talimatlara uyulmaması, hafif veya orta derecede yaralanmayla ve donanım hasarıyla sonuçlanabilir.</p>

- Aküleri ateşe atmayın. Akü patlayabilir.
- Aküleri açmayın veya onlara hasar vermeyin. Açığa çıkan elektrolit cilde ve gözlere zarar verebilir ve toksik olabilir.
- Akülerin bakımı aküler ve gerekli önlemler konusunda bilgi sahibi personel tarafından veya onların gözetimi altında yapılmalıdır.
- Schneider Electric, bakım gerektirmez, sızdırmaz kurşun asitli piller kullanır. Normal kullanım koşullarında akülerin iç bileşenleriyle hiçbir temas yoktur. Aşırı şarj etme, aşırı ısınma veya pillerin başka şekilde hatalı kullanımı pil elektrolitinin boşalmasıyla sonuçlanabilir. Açığa çıkan elektrolit zehirlidir, cilde ve gözlere zarar verebilir.
- İKAZ: Aküleri değiştirmeden önce kolye, kol saati ve yüzük gibi iletken takıları çıkarın. İletken malzemeler üzerinden yüksek enerji geçmesi şiddetli yanıklara neden olabilir.

Radyo Frekans Uyarıları

Bu cihaz kategori C2 UPS ürünüdür. Bu ürün yerleşim bölgelerinde radyo parazitine neden olabilir; bu durumda kullanıcının ek önlemler alması gerekebilir.

Ürün Tanımı

Schneider Electric Easy UPS yüksek performansa sahip kesintisiz güç kaynağıdır (UPS). UPS, elektrik kesintilerine, voltaj düşüklüğüne, elektrik akım yükselişiyle düşüşüne, küçük elektrik güç dalgalanmalarına ve büyük parazitlere karşı elektronik cihazı korur. UPS, şebeke gücü normal düzeylere dönene veya aküler tamamen boşalana kadar bağlı donanıma yedek güç de sağlar.

Bu kullanım kılavuzu sağlanan Belge CD'sinde ve www.apc.com adresindeki Schneider Electric web sitesinde bulunabilir.

Ambalaj İçeriği

UPS montajından önce Güvenlik Kılavuzunu okuyun.

Paket geri dönüşümlüdür; tekrar kullanmak üzere saklayın veya uygun bir biçimde elden çıkarın.

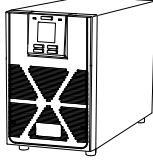

(1)
UPS



(1)
Kullanıcı Elkitabı



(1)
Yazılım, Kullanıcı belgeleri
CD'si



(1)
USB kablosu



(1*)
Şebeke gücü kablosu



(1**)
Çıkış kablosu



(1)
RS-232 kablosu

*: Yerel giriş fişine bağlı olarak seçilir.

** : Yalnızca IEC çıkışı (10 A) bulunan modeller için.

NOT: Model ve seri numaraları üst kapaktaki küçük bir etikette bulunur.

Opsiyonel Aksesuarlar

İsteğe bağlı aksesuarlar için www.apc.com adresindeki Schneider Electric web sitesine başvurun.

Teknik Özellikler

Çevresel Teknik Özellikler

BİLGİ



EKİPMAN HASARI RİSKİ

- UPS yalnızca kapalı alanlarda kullanılmalıdır.
- Kurulum konumu, UPS'nin ağırlığına dayanacak sağlamlıkta olmalıdır.
- UPS'yi aşırı tozlu veya belirtilen sınırların dışında sıcaklık ya da nem bulunan ortamlarda çalıştırmayın.

Bu talimatlara uyulmaması ekipmanın hasar görmesine neden olabilir.

Sıcaklık	Çalıştırma	Tanımlı yükte 0° ila 40°C. En fazla yük kapasitesinin %80'ine doğrusal olarak düşürülmüş şekilde 40° ila 50°C.	Bu ünite, sadece kapalı alanda kullanım amacıyla tasarlanmıştır. Bu ağırlığı taşıyabilecek sağlam bir yer seçin. UPS'yi aşırı tozlu veya belirtilen sınırların dışında sıcaklık ya da nem bulunan ortamlarda çalıştırmayın. Not: Akü modüllerini saklama sırasında altı ayda bir şarj edin.
	Saklama	-20° ila 50°C	
Yükseklik	Çalıştırma	0 - 1.000 m: normal çalışma 1.000 - 3.000 m: Yük, her 100 m yükseklik artışında @ %1 düşer > 3.000 m: UPS çalışmayacaktır	
	Saklama	0 - 15.000 m	
Nem		%0 - 95 bağıl nem, yoğunlaşmayan	

Fiziksel Özellikler

UPS Modeli	SRVS 1000VA	SRVS 2000VA	SRVS 3000VA
Ambalajla birlikte boyutlar Genişlik x Yükseklik x Derinlik	235 mm (9,25 inç) x 330 mm (12,99 inç) x 365 mm (14,37 inç)	235 mm (9,25 inç) x 355 mm (13,98 inç) x 525 mm (20,67 inç)	325 mm (12,8 inç) x 465 mm (18,31 inç) x 565 mm (22,24 inç)
Ambalajsız boyutlar Genişlik x Yükseklik x Derinlik	145 mm (5,7 inç) x 223 mm (8,78 inç) x 288 mm (11,34 inç)	145 mm (5,7 inç) x 238 mm (9,37 inç) x 400 mm (15,75 inç)	190 mm (7,5 inç) x 336 mm (13,2 inç) x 425 mm (16,7 inç)
Ambalajla birlikte ağırlık	10,6 kg	18,1 kg	29 kg
Ambalajsız ağırlık	9,3 kg	16,8 kg	26,8 kg
Kaldırma yönergeleri	< 18 kg (< 40 lb) 	18 - 32 kg (40 - 70lb) 	18 - 32 kg (40 - 70lb) 

Giriş/Çıkış Teknik Özellikleri

UPS Modeli	SRVS 1000VA	SRVS 2000VA	SRVS 3000VA	
Giriş	Voltaj			
	230 Vac Nominal			
	Frekans			
	40 – 70 Hz			
	Giriş Gerilimi Aralığı (%100 yük)			
	160 Vac - 280 Vac			
Giriş Gerilimi Aralığı (%50 yük)				
110 – 285 Vac				
Giriş Gücü Faktörü (%100 dirençli yük)				
Yeşil modda $\geq 0,99$ Normal modda $\geq 0,93$				
Giriş Koruması				
Giriş devre kesici				
Çıkış	UPS Kapasitesi	1000 VA / 800 W	2000 VA / 1600 W	3000 VA / 2400 W
	Nominal Çıkış Voltajı	230 Vac		
	Diğer Programlanabilir Gerilim	220 Vac, 240 Vac		
	Tanımlı yükte verimlilik	En fazla %88		
	Çıkış Gerilimi Düzenlemesi	$\pm \%1$ statik		
	Çıkış Gerilimi Bozulması	<ul style="list-style-type: none"> Tam doğrusal yük için en fazla %3, Tam RCD yükü (%100 VA, 0,8 PF) için en fazla %6 Yedek süresinin son 60 saniyesi için %15 (yalnızca dâhilî akü için tam yükte) 		
	Frekans – Aküyle Çalışma	50 Hz $\pm \%0,5$ veya 60 Hz $\pm \%0,5$		
	Frekans – AC Modunda	50 Hz ± 3 Hz veya 60 Hz ± 3 Hz		
	Tepe Faktörü	3:1		
	Dalga Biçimi	Sinüs Dalgası		
	Çıkış bağlantıları	Lütfen arka panel özelliklerine başvurun		
	Bypass	Dâhilî atlama		

Akü

UPS Modeli	SRVS 1000VA	SRVS 2000VA	SRVS 3000VA
Yapılandırma	Dâhilî akü		
Tip	Kapalı, bakım gerektirmez (SMF) 12 V, 9 Ah		
Akü Bankası Gerilimi	24 V	48 V	72 V

Ön Panel Göstergesi

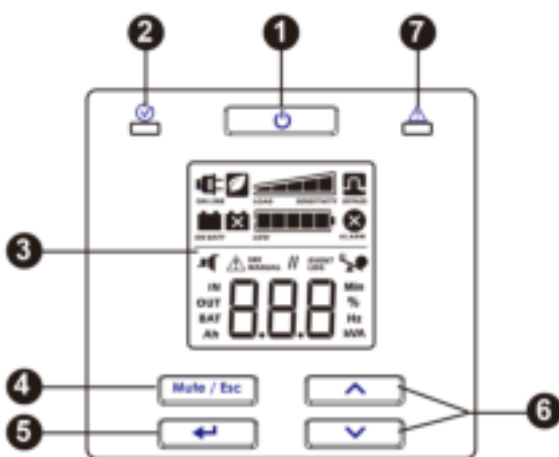

- 1 UPS Açma/Kapatma düğmesi
- 2 Durum LED'i
- 3 LCD Ekran
- 4 Sessiz/Çıkış düğmesi
- 5 Enter düğmesi
- 6 Yukarı/Aşağı düğmeleri
- 7 Alarm LED'i

Arka Panel Özellikleri

SRVS 1000VA

Model	Çıkış tipi ve miktarı
SRVS1KI	 x 3

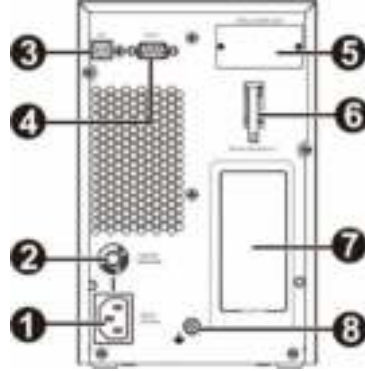

- | | | | |
|---|----------------------|---|--|
| 1 | AC girişi | 5 | Akıllı kart yuvası |
| 2 | Giriş devre kesici | 6 | Akü bağlantı kesici |
| 3 | USB bağlantı noktası | 7 | Çıkış Grubu (sol taraftaki çıkış tipi ve miktarı kısmına başvurun) |
| 4 | RS-232 | 8 | Topraklama Vidası |

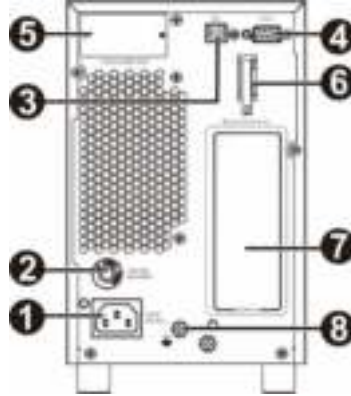

SRVS 2000VA

Model	Çıkış tipi ve miktarı
SRVS2KI	 x4



- | | | | |
|---|----------------------|---|--|
| 1 | AC girişi | 5 | Akıllı kart yuvası |
| 2 | Giriş devre kesici | 6 | Akü bağlantı kesici |
| 3 | USB bağlantı noktası | 7 | Çıkış Grubu (sol taraftaki çıkış tipi ve miktarı kısmına başvurun) |
| 4 | RS-232 | 8 | Topraklama Vidası |

SRVS 3000VA

Model	Çıkış tipi ve miktarı
SRVS3KI	 x6
	 x1

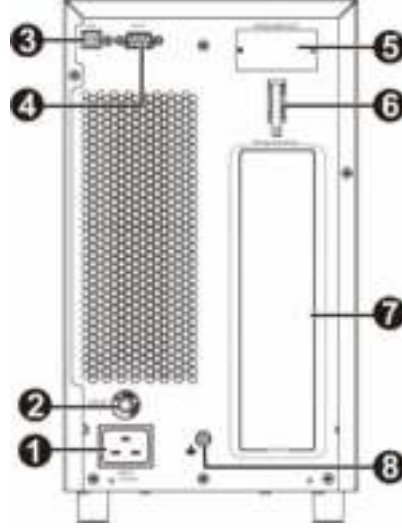

- | | | | |
|---|----------------------|---|--|
| ❶ | AC girişi | ❺ | Akıllı kart yuvası |
| ❷ | Giriş devre kesici | ❻ | Akü bağlantı kesici |
| ❸ | USB bağlantı noktası | ❼ | Çıkış Grubu (sol taraftaki çıkış tipi ve miktarı kısmına başvurun) |
| ❹ | RS-232 | ❽ | Topraklama Vidası |

Temel Konnektörler



UPS ile birlikte, güç denetleme yazılımı ve arabirim takımları kullanılabilir.

Yalnızca Schneider Electric tarafından sağlanmış veya onaylanmış arabirim takımlarını kullanın.

Bu UPS dâhilî aküyle donatılmıştır. UPS, fabrikadan aküler bağlanmamış olarak nakledilir. UPS'yi açmadan önce, lütfen kulpu yukarı çekip, ardından ünitenin içine iterek aküyü bağlayın.

Çalıştırma Ayarları

Aküyü takın

Akü kulpunu yukarı çekip, ardından ünitenin içine iterek aküyü bağlayın.

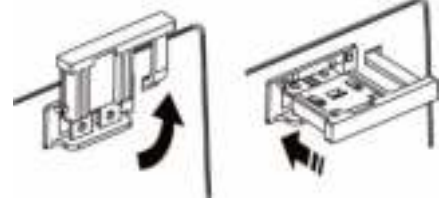

UPS'ye gücü ve donanımı bağlayın



ELEKTRİK ÇARPMASI TEHLİKESİ

- Tüm elektrik işleri yetkili bir elektrikçi tarafından yapılmalıdır.
- Donanım üzerinde çalışmaya başlamadan önce, bu donanıma gelen tüm güç bağlantılarını kapatın. Kilitleme/Etiketleme prosedürlerini uygulayın.
- Elektrikli donanım üzerinde çalışırken takı takmayın.

Bu talimatlara uyulmaması, hafif veya orta derecede yaralanmayla sonuçlanabilir.

1. Cihazları UPS'ya bağlayın. Uzatma kablosu kullanmaktan kaçının.
2. Giriş şebeke gücünü UPS'ye bağlayın.
3. Giriş şebeke gücünü açın. Şebeke gücü verildiğinde UPS ekran paneli aydınlanacaktır.

UPS'yi Çalıştırın

UPS'nin ön panelinde bulunan  düğmesine basın.

- İlk beş saatlik normal çalışma sırasında akü %90 kapasiteye şarj olur.
- Bu ilk şarj döneminde akünün tam kapasitede çalışmasını **beklemeyin**.



UPS'yi soğuk başlatma

Bağlı ekipmana UPS akülerinden güç sağlamak için Soğuk Başlatma özelliğini kullanın.

 düğmesine basın. Ekran paneli aydınlanacaktır. Bağlı donanıma akü gücü sağlamak için  düğmesine tekrar basın.

Yönetim yazılımını bağlayın ve yükleyin

Easy UPS SRVS, gözetimsiz işletim sistemi kapatma, UPS izleme, UPS denetimi ve enerji raporlama için SchneiderUPS yönetim yazılımıyla birlikte sağlanır. Aşağıdaki şema, tipik bir sunucu kurulumunun gösterimidir.

1. UPS'nin arkasından  gelen USB kablosunu sunucu gibi bir korumalı aygıta bağlayın.
2. Sunucu veya işletim sistemine sahip başka bir aygıt için, SchneiderUPS CD'sini yerleştirin ve ekrandaki kurulum talimatlarını izleyin.
3. Seri kabloyla ek iletişim seçenekleri için bir yerleşik seri bağlantı noktası da  vardır.
4. Yerleşik akıllı kart yuvası aracılığıyla daha da fazla iletişim seçeneği kullanılabilir. Daha fazla bilgi için www.apc.com adresine başvurun.

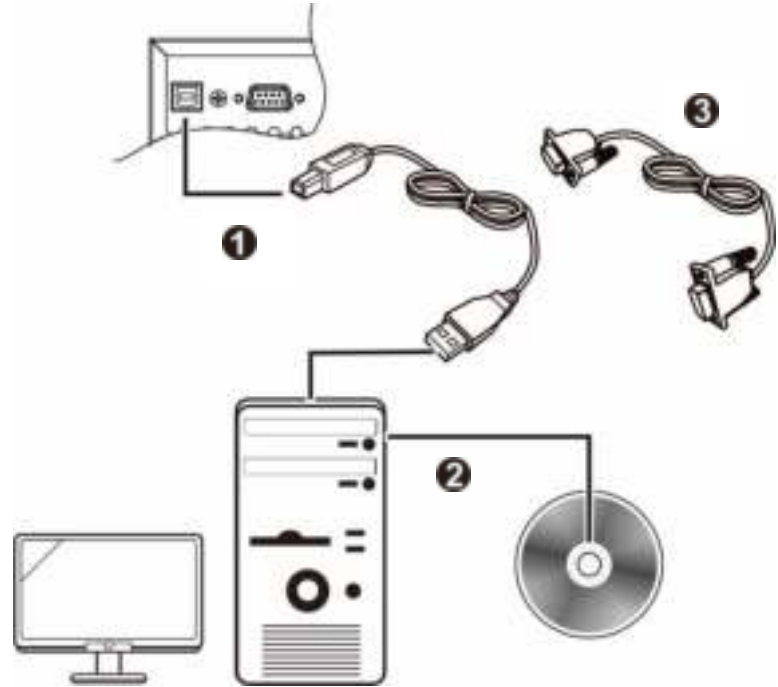







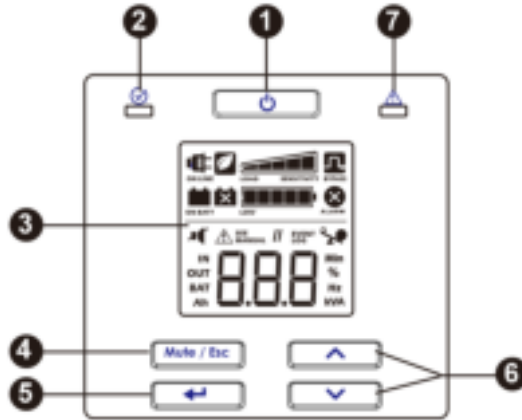

Çalışma

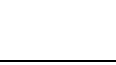







Ekranın Kullanılması

Bu Easy UPS modelleri sezgisel ve yapılandırılabilir bir LCD ekranla donatılmıştır. Bu ekran, aynı bilgileri aktarmalarından dolayı yazılım arayüzünü tamamlar ve UPS ayarlarını yapılandırmak için herhangi biri kullanılabilir. Ekran aşağıdaki tuşlardan ve göstergelerden oluşur:



1	UPS Açma/Kapatma düğmesi 	<ul style="list-style-type: none"> • UPS'yi açmak için bu tuşa basın. • UPS'yi kapatmak için, bir uyarı sesi duyana kadar bu düğmeyi basılı tutun. • Alarmları sıfırlamak için bu düğmeye basın.
2	Durum LED'i 	Güç açıkken Durum LED'i yeşil renkte yanar. Bu LED, çıkış gücünün iki farklı durumunu belirtir: <ul style="list-style-type: none"> • Çıkış kapalı: LED yanıp söner. Çıkış gücünü açmak için Açma/Kapatma düğmesine basın. • Çıkış açık: LED sürekli yeşil renkte yanar.
3	LCD Ekran 	Ekran arayüzü seçenekleri bu LCD ekranda görülebilir. Ekran aydınlık değilse, LCD ekranı etkinleştirmek için  veya  düğmesine basın.
4	Sessiz/Çıkış düğmesi 	<ul style="list-style-type: none"> • Sesli alarmları onaylamak ve geçici olarak gizlemek içindir. • Bir alt menüden çıkmak ve ana menüye dönmek içindir.
5	Enter düğmesi 	Menüye girmek veya gezinme sırasında bir menü öğesini/değeri seçmek için bu düğmeye basın.
6	Yukarı/Aşağı düğmeleri 	Ana menü seçenekleri ve görüntüleme ekranları boyunca ilerlemek için bu iki düğmeye basın.
7	Alarm LED'i 	Bu Alarm LED'i , UPS bir hata algıladığında kırmızı renkte yanar ve UPS bildirimleri için kırmızı renkte yanıp söner. Bu kılavuzun 11. sayfasındaki “Alarmlar ve Bildirimler” kısmına bakın.

LCD Ekran Simgeleri

 ON LINE	Çevrimiçi: UPS, şebeke gücünü kullanıyor ve bağlı donanıma güç sağlamak için çift dönüştürme gerçekleştiriyor.
 ON BATT	Aküyle Çalışma: UPS, bağlı ekipmanlara akü yedek gücünü sağlamaktadır.
 AKÜYÜ DEĞİŞTİR	Aküyü Değiştir: Akü güvenli biçimde bağlı değil veya hizmet ömrünün sonuna yaklaşıyor ve değiştirilmesi gerekli.
 BYPASS	Bypass: UPS bypass modunda olup şebeke gücünü doğrudan takılı ekipmanlara aktarmaktadır. Atlama modu çalışması, bir dâhilî UPS olayının veya aşırı yük durumunun sonucudur. UPS bypass konumunda olduğu sürece akü desteği sağlanmaz. Bu kılavuzun 11. sayfasındaki “Alarmlar ve Bildirimler” kısmına bakın. Bu simge, Yeşil Mod simgesiyle birlikte görüldüğünde UPS'nin yeşil mod çalışmasında olduğunu belirtir.
 ALARM	Sistem Alarmları: Bir dâhilî hata algılanır. Bu kılavuzun 11. sayfasındaki “Alarmlar ve Bildirimler” kısmına bakın.
	Aşırı Yük: UPS'ye bağlı donanım, tanımlanandan daha fazla güç çekiyor.
 LOW	Akü Şarjı: Akü şarj düzeyi, yanan çubuk kısımlarının sayısı ile belirtilir. Beş bloğun tamamı aydınlatıldığında, akü tam şarj olur. Her bir çubuk akü şarj kapasitesinin yaklaşık %20'sini temsil eder.
 LOAD SENSITIVITY	Yük Düzeyi: Yük yüzdesi, yanan yük çubuğu kısımlarının sayısı ile belirtilir. Her bir çubuk en fazla yük kapasitesinin yaklaşık %20'sini temsil eder.
	Sessiz: Simgede aydınlatılan hat duyulabilir alarmin devre dışı bırakıldığını gösterir.



Yeşil Mod: Yanan bir simge, ünitenin Yeşil modda çalıştığını belirtir. Bağlı donanım, giriş gerilimi ve frekans yapılandırılan sınırlar içinde olduğu sürece şebeke girişini doğrudan alır.



Alarm veya bildirim: UPS bir hata algılamıştır veya yapılandırma modundadır. Bu kılavuzun 11. sayfasındaki “Alarmlar ve Bildirimler” kısmına bakın.

EVENT LOG



Olay: Kullanıcı olay günlüğünü görüntülerken bu simge yanar.

Alarmlar ve Sistem Hataları

Durum Göstergeleri

Sürekli uyarı sesleri, her yarım saniye	Düşük Akü Durumu - Akü tamamen boşalma durumuna yaklaşıyor. UPS kapanmak üzere.
Her 30 saniyede 4 uyarı sesi (ilk uyarı sesi, aküyle çalışmaya geçildikten 4 saniye sonra başlar)	Aşırı Yük Durumu - UPS'ye bağlı donanım, tanımlanandan daha fazla güç çekiyor.
Sesli uyarı sürekli açık	Aküyle Çalışma Durumu - UPS, bağlı donanıma akü yedek gücü sağlıyor.
Her 2,5 saniyede kısa uyarı sesi	Alarm Durumu - UPS bir hata algıladı. Bu kılavuzdaki “Alarmlar ve Bildirimler” kısmına bakın.
1 dakika boyunca her yarım saniyede sürekli kısa uyarı sesleri, her 5 saatte tekrarlama.	Akü bağlantısı kesildi.
Her 5 saniyede iki kısa uyarı sesi	Bozuk akü (değiştirin)
	Olay Atlama Durumu - UPS bir hata algıladı. Bağlı donanım, atlama rölesi aracılığıyla şebeke giriş gücü alır.

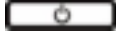
Alarmlar

Görüntüleme kodu	Açıklama	Çözüm
SC	UPS, çıkışta bir kısa devre yaşadı. Ünite bu durumdan otomatik olarak kurtarmayı deneyecektir.	UPS çıkışında herhangi bir kısa devre olup olmadığını kontrol edin. Kısa devreyi giderin, ünitenin otomatik olarak kurtarmasını bekleyin veya UPS'yi başlatmak için  düğmesine basın. Not: UPS bu durumda olduğunda, bağlı donanıma sağlanan güç düşer.
OL	UPS bir aşırı yük durumu yaşıyor.	Aşırı yüklenme durumunu gidermek için gereksiz ekipmanların UPS ile olan bağlantısını kesin.
dCH	UPS bir DC gerilimi hatası algıladı. Ünite bu durumdan otomatik olarak kurtarmayı deneyecektir.	UPS otomatik olarak kurtaramazsa Schneider Electric ile iletişime geçin.
Hot	Ünitenin sıcaklığı ayarlanan sınırların üzerine çıkıyor.	UPS yükünü düşürmek için gereksiz donanımların UPS ile olan bağlantısını kesin. Ortam sıcaklığının sınırlar içinde olduğundan emin olun. Yeterli boşluk sağlandığından emin olun.
CHG	UPS bir şarj edici hatası algıladı.	UPS akü terminalinde herhangi bir kısa devre olmadığını doğrulayın. UPS'yi başlatmak için  düğmesine basın.



Tüm diğer alarm kodları için Schneider Electric ile iletişime geçin.

Bildirimler

Görüntüleme kodu	Açıklama	Çözüm
bdc	Akü bağlı değil	Aküyü UPS'ye bağlayın. Bu kılavuzun 8. sayfasındaki “Çalıştırma” kısmına bakın.

UPS Görüntüleme Parametreleri

Çalışmayla ilgili olarak, ekran panelinde görüntülenen veriler tabloda verilmektedir.















 veya  düğmesini kullanarak gezinin.

Parametre	Birimler	Gösterge Simgeleri
Çıkış gerilimi	Vac	OUT, V
Çıkış frekansı	Hz	OUT, Hz
Giriş Voltajı	Vac	IN, V
Giriş frekansı	Hz	IN, Hz
Akü voltajı	V DC	BAT, V
Ortam sıcaklığı	° C	SAYI, C
Akü şarjının durumu	%	BAT, %
Yüzde olarak yük düzeyi (En Fazla Vat veya VA)	%	OUT, %
kVA olarak yük düzeyi	kVA	OUT, kVA
Bağlı akünün toplam Ah kapasitesi	Ah	BAT, Ah
Aküyle Çalışmada kalan süre	Dakika	BAT, Min

Yapılandırma

UPS Parametrelerini Yapılandırın

UPS'deki parametreleri yapılandırmak için aşağıdaki adımları izleyin:



-  düğmesine basın.
- “Set” kısmına gitmek için  veya  düğmesine basın.
-  düğmesine basın.
-  veya  düğmesini kullanarak parametreler boyunca gezin.
- Bir parametreyi düzenlemek için  düğmesine basın. Simgeler, düzenlemeyi belirtmek için yanıp sönmeye başlar.
- Seçilen parametreye yönelik kullanılabilir seçenekler arasında gezinmek için  veya  düğmesine basın.
- Seçeneği belirlemek için  düğmesine veya geçerli parametrenin düzenlenmesini iptal etmek için  düğmesine basın. Bu işlemden sonra simgelerin yanıp sönmesi durur.
- Parametreler arasında gezinmek için  veya  düğmesine basın.
- Menüden çıkmak için  düğmesine basın.















UPS Ayarları

UPS ayarlarını ekran arayüzünü kullanarak yapılandırın. Parametreleri düzenlemek için “UPS Parametrelerini Yapılandırın” kısmına bakın.

İşlev	Fabrika Ayarı	Kullanıcının Belirleyebileceği Seçenekler	Açıklama
Çıkış gerilimi	230 Vac	220, 230, 240 Vac	Kullanıcının, UPS çevrimiçi çalışırken çıkış gerilimini seçmesini sağlar.
Sesli Alarm	Etkinleştir	Etkinleştir, Engelle	Devre dışı olarak ayarlandığında veya ekran panelinde MUTE düğmesine basıldığında, UPS sesli alarmları sessize alacaktır.
Yeşil mod/yüksek verimlilik modu	Devre dışı	Etkinleştir/Engelle	Bu mod etkinleştirildiğinde, bağlı donanım, giriş gerilimi yapılandırılan çıkış geriliminin $\pm 5\%$ ve yapılandırılan çıkış frekansının ± 3 Hz aralığında olduğu sürece şebeke giriş gücünü atlama rölesi aracılığıyla alır. Bu mod sırasında dönüştürücü kapatılır. Şebeke gücü girişi aralık dışına çıkarsa dönüştürücü açılır. Yük, çevrimiçi moda veya pil moduna aktarılır. Bağlı donanıma giden güç 10 milisaniyeye kadar kesilebilir.
Ayarı yeniden başlatmak için en az akü kapasitesi	%0	%0, %15, %50, %90	Akü, bu ayarla yapılandırılan çalışma süresini sağlayabileceği bir düzeye şarj olana kadar UPS çıkışı açılmayacaktır. %0 olarak yapılandırılırsa, UPS çıkışı, şebeke gücünün geri gelmesinden hemen sonra açılır.
Düşük akü durumu göstergesi ayarı	2 dk.	2 dk., 5 dk., 7 dk., 10 dk.	Asıl çalışma süresi son kullanıcı tarafından ayarlanan sınıra ulaştığında UPS sesli alarm çalacaktır. Sesli alarm yalnızca UPS akü modunda çalışırken çalınacaktır.

Gelişmiş Ekran Gezintisi



UPS ekranında ana menüde beş tane seçenek ve iki tane alt menü seçeneği vardır. Bu menü seçeneklerine erişmek için ana ekranda  düğmesine basın. Menü seçenekleri arasında gezinmek için  veya  düğmesini kullanın.

Menü Seçeneği	Açıklama
SEt	UPS'yi Yapılandırın UPS parametrelerini yapılandırmak için bu menü seçeneğini kullanın. Yapılandırma seçeneklerini görmek için  düğmesine basın. Ayrıntılar için 13. sayfadaki “UPS Parametrelerini Yapılandırın” kısmına bakın. Ana ekrana dönmek için  düğmesine basın.
LOG	Olay Günlüğünü Gösterin UPS olay günlüğünü görmek için bu menü seçeneğini kullanın. UPS son 10 olayı kaydeder ve kodları bu günlükte görüntüler. Günlüğü görmek için  düğmesine basın. Günlüğe kaydedilen olayları görmek için  veya  düğmesini kullanın.  düğmesi eski olaylara,  düğmesi de yeni olaylara doğru ilerletir. Her günlük girişi bir sayısal ve metinsel olay koduna sahiptir. Günlüğün sonunda “End” sözcüğü görüntülenecektir. Ana ekrana dönmek için  düğmesine basın.
UPS	UPS Bilgilerini Gösterin UPS bilgilerini görmek için bu menü seçeneğini kullanın. UPS'nin derecelendirmesini görmek için  düğmesine basın. UPS aygıt yazılımı sürümünü görmek için  düğmesine basın. Ana ekrana dönmek için  düğmesine basın.
bYP	Atlama için Kullanıcı Komutu UPS'yi atlama moduna geçirmek veya atlama modundan çevrimiçi moda almak için bu menü seçeneğini kullanın.  düğmesine basın: Put UPS'yi atlama modu çalışmasına geçirmek için kullanın. Not: Şebeke gerilimi eşik sınırları içinde değilse, bağlı donanıma giden güç düşecektir. Çıkış: UPS'yi atlama modundan çıkarın ve bağlı donanıma temiz gücü geri verin.
tSt	Akü Kendi Kendine Sınamayı Gerçekleştirin Bir kendi kendine sınama gerçekleştirmek ve akü durumunu belirlemek için bu menü seçeneğini kullanın. Sınamayı başlatmak için  düğmesine basın. Sınama komutu kabul edilirse, UPS bir kendi kendine sınama başlatacak ve ekranda geri sayım gösterecektir. Sınamanın sonunda ekran mesajları gösterilir. rFd Sınama reddedildi. Çıkış kapalı veya akü şarj olmamış. Fl d Sınamadan geçmedi. PAS Sınamadan geçti. Abt İç nedenlerden dolayı sınama iptal edildi. Ana ekrana dönmek için  düğmesine basın.

Arıza Giderme

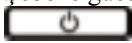
Montaj ve çalıştırmayla ilgili küçük sorunları çözmek için aşağıdaki tabloyu kullanın. UPS ile ilgili karmaşık sorunlara ilişkin yardım için www.apc.com adresindeki Schneider Electric web sitesine başvurun.

Sorun ve/veya Muhtemel Neden	Çözüm
Şebeke girişi varken veya hiç güç çıkışı yokken UPS açılmıyor	
UPS açılmamış.	UPS'yi açmak için  düğmesine basın.
UPS şebeke elektrik kaynağına bağlanmamıştır.	UPS'den şebeke elektrik kaynağına uzanan kabloyu kontrol edip her iki ucundaki bağlantıların gerektiği gibi yapılmış olup olmadığını denetleyin. Bu kılavuzun 8. sayfasındaki “Çalıştırma” kısmına bakın.
UPS'deki giriş termal devre kesici şalteri atmış.	Arka paneldeki giriş termal devre kesici sıfırlama düğmesine basın.
UPS fişe takıldığında aküden çalışıyor.	
Yüksek, düşük veya bozuk giriş gerilimi ya da frekansı var.	UPS'yi farklı bir devredeki farklı bir prize bağlayın. Ünitenin giriş gücü aldığından emin olmak için şebeke giriş gücünü sınavın. Ekran açıksa, menüye girip, giriş gerilimini ve frekansını kontrol edin.
Aküye bağlıken, UPS bağlı donanıma güç sağlamıyor	
UPS açılmamış.	UPS kapatılmışsa (ekran açık değilse), 8. sayfadaki “UPS'yi soğuk başlatma” prosedürünü izleyin.
Akü bağlanmamış.	Aküyü UPS'ye bağlayın. Bu kılavuzun 8. sayfasındaki “Çalıştırma” kısmına bakın.
Düşük akü kesintisi. UPS, şebeke gücü kesintisinden dolayı aküyü boşaltmış ve düşük akü durumundan dolayı çıkışı kapatmış olabilir.	Şebeke gücünün geri gelmesini bekleyin ve aküyü şarj edin. Şebeke gücü geri geldikten sonra çıkış gücünü açmak için  düğmesine basın.
UPS uzun aralıklarla bir uyarı sesi çalıyor	
UPS, aküyle normal biçimde çalışıyor.	UPS bir hata algılamış. Bu kılavuzun 11. sayfasındaki “Alarmlar ve Bildirimler” kısmına bakın.
Alarm LED'i yanıyor. UPS bir alarm mesajı görüntülüyor ve sürekli bir uyarı sesi çalıyor	
UPS bir hata algılamış.	Bu kılavuzun 11. sayfasındaki “Alarmlar ve Bildirimler” kısmına bakın.
Uyarı LED'i yansa bile UPS hiçbir sesli uyarı çalmıyor	
Sesli alarm devre dışı bırakılmış.	Sesli alarmları etkinleştirmek için UPS yapılandırmasını değiştirin.
UPS beklenen destek süresini sağlamıyor.	
Yakın zamandaki bir güç kesintisinden dolayı UPS aküsü boşalmış.	Uzun süreli elektrik kesintilerinden sonra akülerin şarj edilmesi gerekmektedir. Aküler, uygun biçimde yeniden şarj olmadan devreye girdiklerinde veya yüksek sıcaklıklarda çalıştıklarında ömürleri kısalmır.
Akü, hizmet ömrünün sonuna yaklaşıyor.	Akü, hizmet ömrünün sonuna yaklaşıyorsa, aküyü değiştirme göstergesi yanmasa bile aküyü değiştirmeyi göz önünde bulundurun. Bu kılavuzun 8. sayfasındaki “Çalıştırma” kısmına bakın.

Sorun ve/veya Muhtemel Neden	Çözüm
UPS kapanmıyor	
KAPATMA düğmesine düzgün biçimde basılmamış.	UPS'yi kapatmak için, bir uyarı sesi duyana kadar  düğmesini basılı tutun.
Şebeke giriş gücü var.	Şebeke giriş gücü varsa UPS mantık gücü kapatılamaz. UPS'yi kapatmak için, şebeke giriş gücünü kapatıp  düğmesine basın. Bir uyarı sesi duyduğunuzda basmayı bırakın.
UPS Atlama modunda ve LED kırmızı renkte yanmıyor.	
UPS yeşil modda.	İstemiyorsanız yeşil modu devre dışı bırakın.
UPS, atlama modunda kalmak üzere yapılandırılmış.	Atlama modundan çıkmak için yapılandırmayı değiştirin.
UPS, aşırı sıcaklık alarmı giderildikten sonra bile atlama modunda.	UPS'yi çevrimiçi moduna getirmek için bağlı yükü %90'ın altına düşürün.
UPS bir aşırı yük durumu yaşamış ve atlama moduna aktarmış.	Bağlı donanım, www.apc.com adresindeki Schneider Electric web sitesinde bulunan teknik özelliklerde tanımlanmış “en fazla yükü” aşıyor. Aşırı yük durumu düzeltilene kadar alarmlar devam eder. Aşırı yüklenme durumunu gidermek için gereksiz ekipmanların UPS ile olan bağlantısını kesin. UPS, atlama modunda olduğu ve devre kesici atmadığı sürece güç sağlamaya devam eder. UPS, şebeke gerilimi kesintisi durumunda akü gücü sağlamayacaktır.
UPS bir hata algılamış ve atlama moduna aktarmış.	Bu kılavuzun 11. sayfasındaki “Alarmlar ve Bildirimler” kısmına bakın.

Nakliye

1. Baęlı tüm ekipmanları kapatın ve baęlantılarını kesin.
2. Ünitenin Őebeke gücü ile baęlantısını kesin.
3. Tüm dahili ve harici akülerin baęlantısını kesin (uygunsa).
4. Bu kılavuzun *Servis* bölümünde verilen nakliyat talimatlarını uygulayın.

Servis

Ünitenin bakıma ihtiyacı varsa bayinize göndermeyin. Őu yolları izleyin:

1. Sıklıkla karşılaşılan sorunları ortadan kaldırmak için kılavuzun *Sorun Giderme* bölümünü inceleyin.
2. Sorun devam ederse **www.apc.com** adresindeki Schneider Electric web sitesi aracılığıyla Schneider Electric Müşteri Hizmetleri ile irtibat kurun.
 - a › Model numarasını, seri numarasını ve satın alma tarihini not alın. Model ve seri numaraları ünitenin arka panelinde yer alır ve bunlara, belirli modellerde LCD ekrandan da ulaşılabilir.
 - b › Müşteri Desteęini arayın. Bir teknisyen, sorunu telefonda çözmeye çalışacaktır. Sorunu telefonda çözmeyiz mümkün deęilse, teknisyen size bir Materyal İade İzni Numarası (RMA No.) verecektir.
 - c › Ünite garanti altındaysa onarım ücretsizdir.
 - d › Servis prosedürleri ve sonuçlar, ülkeye göre deęişiklik gösterebilir. Ülkeye özel talimatlar için **www.apc.com** adresindeki Schneider Electric web sitesine başvurun.
3. Nakliyat sırasında hasar görmemesi için üniteyi düzgün bir şekilde paketleyin. Paketlemek için hiçbir zaman köpük boncuk kullanmayın.
Nakliyat sırasında oluşan hasarlar garanti kapsamına girmez.
Not: Nakletmeden önce, UPS'deki veya harici akü takımındaki akü modüllerinin baęlantılarını mutlaka kesin. Baęlantısı kesilen dâhilî aküler UPS veya harici akü takımı içinde kalabilir.
4. Paketin dışına Müşteri Desteęi tarafından sağlanan RMA (Materyal İade İzni) numarasını yazın.
5. Üniteyi Müşteri Desteęinin verdięi adrese, ödemesini önceden yaparak, sigortalı bir taşıyıcıyla gönderin.

Sınırlı Fabrika Garantisi

Schneider Electric IT Corporation (SEIT), ürünlerinin satın alınma tarihinden itibaren iki (2) yıllık bir süre için malzeme ve işçilik açısından kusursuz olacağını garanti eder. SEIT'in bu garanti altındaki yükümlülüğü, takdir hakkı münhasıran kendisine ait olmak üzere, bu tür kusurlu ürünleri onarmak veya değiştirmektir. Zarar görmüş ürünün/parçanın onarımı ya da değiştirilmesi normal garanti süresini uzatmaz.

Bu garanti sadece, satın alma tarihinden sonra 10 gün içinde Ürünü gerektiği gibi kaydettiren orijinal alıcı için geçerlidir. Ürünler warranty.apc.com adresinden çevrimiçi olarak kaydedilebilir.

Hasarlı ürünün test veya kontrol aşamasında, üründe meydana geldiği iddia edilen arıza bulunamazsa veya bu hasar son kullanıcı veya üçüncü şahıslar tarafından yanlış kullanım; ihmal; hatalı kurulum, test, çalıştırma veya Ürünün SEIT önerileri veya teknik özelliklerine aykırı kullanımı nedeniyle meydana gelmişse ürün garanti kapsamı dışındadır ve SEIT bu ürünle ilgili hiçbir sorumluluk kabul etmez. Ayrıca SEIT, şunlardan kaynaklanan kusurlar için sorumlu tutulamaz: 1) yetkili olmayan kişiler tarafından ürün üzerinde yapılan onarım veya değişiklik, 2) yanlış veya uygun olmayan voltaj veya bağlantı, 3) uygunsuz çalışma şartları, 4) doğal afet, 5) dış etkenlere aruz kalması ve 6) hırsızlık. Bu garanti kapsamında SEIT'in, seri numarası değiştirilmiş, tahrif edilmiş veya silinmiş ürünler ile ilgili olarak hiçbir sorumluluğu yoktur.

YUKARIDA AKSİ BELİRTİLMEDİKÇE, YASANIN UYGULANIŞI YA DA BAŞKA BİR ŞEKİLDE KULLANILAN YA DA İŞBU SÖZLEŞME UYARINCA VEYA SÖZLEŞMEYE BAĞLI OLARAK SATILAN, BAKIMI YAPILAN YA DA VERİLEN ÜRÜNLERİN AÇIK VEYA ZİMNİ GARANTİLERİ YOKTUR. SEIT TİCARİ DEĞER, KALİTE MEMNUNİYETİ VE BELİRLİ BİR AMACA UYGUNLUK İLE İLGİLİ BÜTÜN DOLAYLI GARANTİLERİ REDDEDER.

SEIT ÜRÜNLERLE İLGİLİ TEKNİK YA DA BAŞKA TÜRLÜ ÖNERİ YA DA HİZMET VERSE DE SEIT ZİMNİ GARANTİ KAPSAMLARI GENİŞLETİLMEMEYECİK, DARALTILMAYACAK, ETKİLENMEYECİK VE HİÇ BİR SORUMLUK YA DA YÜKÜMLÜLÜK ORTAYA ÇIKMAYACAKTIR.

YUKARIDAKİ GARANTİLER VE BAŞVURU YOLLARI; TÜM DİĞER GARANTİ VE BAŞVURU YOLLARINI HARİÇ TUTAR VE ONLARIN YERİNİ ALIR. YUKARIDA BELİRTİLEN GARANTİLER SEIT'İN TEMEL SORUMLULUĞUNU OLUŞTURMAKTA VE ALICININ BU TÜR GARANTİLERİN İHLALİNDEKİ TEK ÇÖZÜM SAĞLAYICISI DURUMUNA GETİRMEKTEDİR. SEIT SADECE SATIN ALAN İLK KİŞİNİN PROBLEMİNİ ÇÖZMEYİ GARANTİ EDER, ÜÇÜNCÜ KİŞİLERE ÇÖZÜM BULMAKLA SORUMLU DEĞİLDİR.

HATADAN YA DA HAKSIZ FİİLDEN ORTAYA ÇIKSIN YA DA ÇIKMASIN, HATALARA, İHMALE, SINIRLI YÜKÜMLÜLÜĞÜNE BAKMAKSIZIN BİR HASAR OLASILIĞININ ORTAYA ÇIKIŞINDA; SEIT ÖNERİLMİŞ OLSA BİLE SEIT, GÖREVLİLERİ, YÖNETİCİLERİ, YAN KURULUŞLARI, İŞÇİLERİ HİÇ BİR ŞEKİLDE ÜRÜNÜN SERVİS VE MONTAJI DIŞINDA KULLANIMDAN KAYNAKLANAN; DOLAYLI, ÖZEL, İKİNCİL YA DA CEZA OLARAK GÖRÜLEN TAZMİNATLARDAN SORUMLU OLMAYACAKTIR. SEIT ÖZELLİKLE KÂR VEYA GELİR KAYBI (DOĞRUDAN VEYA DOLAYLI), EKİPMAN KAYBI, EKİPMANDA KULLANIM KAYBI, YAZILIM KAYBI, VERİ KAYBI, VEKALET MALİYETLERİ, ÜÇÜNCÜ ŞAHISLAR TARAFINDAN AÇILABİLECEK DAVALAR GİBİ MASRAFLARDAN SORUMLU DEĞİLDİR.

BU SINIRLI GARANTİ KAPSAMINDAKİ HİÇBİR ŞEY İHMAL VEYA YALAN BEYAN SONUCUNDA OLUŞAN ÖLÜM YA DA KİŞİSEL YARALANMA İÇİN 'Yİ SORUMLULUK DIŞINDA TUTMA VEYA SEIT'İN SORUMLULUĞUNU SINIRLANDIRMA AMAÇLI DEĞİLDİR; SORUMLULUK DIŞINDA KALMA VEYA SORUMLULUĞU SINIRLANDIRMA KONUSUNDA YÜRÜRLÜKTEKİ YASALARA BAŞVURULUR.

Garanti altında servis elde etmek için müşteri desteği bölümünden bir Materyal İade İzni (RMA) numarası almanız şarttır. Garanti talebinde bulunmak isteyen müşteriler, konu ile ilgili olarak SEIT web sitesi (www.apc.com) aracılığıyla Schneider Electric uluslararası müşteri destek ağına ulaşabilir. **www.apc.com**. Ülke seçimi açılır menüsünden ülkenizi seçin. Bölgenizdeki müşteri destek bilgisine ulaşmak için web sayfasının en üstündeki Destek sekmesini açın. Ürünlerin nakliyat ücretleri önceden ödenmiş olarak iade edilmesi ve karşılaşılan sorunun kısa bir tanımı ile satın alma tarih ve yerine ilişkin kanıtın ürünle birlikte gönderilmesi şarttır.

Schneider Electric Dünya apında Mteri Desteęi

Bu ya da dięer Schneider Electric rnleri iin aaęıda belirtilen yntemlerle cretsiz mteri desteęi verilmektedir:

- Schneider Electric Bilgi Tabanındaki dokmanlara erimek ve mteri destek talebinde bulunmak iin Schneider Electric Web sitesini ziyaret edin.
 - **www.apc.com** (irket Merkezi)
Kendilerinden mteri destek bilgisi edinebileceęiniz farklı lkelerin yerel Schneider Electric Web sitelerini inceleyin.
 - **www.apc.com/support/**
Schneider Electric Bilgi Tabanını arama ve e-destek kullanma iin dnya genelinde destek.
- Schneider Electric Mteri Destek Merkezi ile telefon veya e-posta yoluyla irtibat kurun.
 - Yerel, lkeye zel merkezler: İletifim bilgileri iin **www.apc.com/support/contact** adresine gidin.

Blgesel mteri desteęiyle ilgili bilgi iin, Schneider Electric temsilcisiyle veya Schneider Electric rnnz satın aldıęımız dięer daęıtımcılarla irtibat kurun.

Manuale utente della Serie Easy UPS On-Line SRVS 1000VA, 2000VA, 3000VA

Importanti informazioni di sicurezza

Leggere attentamente le istruzioni e osservare l'apparecchiatura per migliorare la conoscenza del dispositivo prima di installarlo, utilizzarlo o sottoporlo a manutenzione. Nel presente documento o nell'apparecchiatura possono apparire i seguenti messaggi speciali per avvertire di potenziali pericoli o per richiamare l'attenzione su informazioni che chiariscono o semplificano una procedura.



L'aggiunta di questo simbolo a un'etichetta di sicurezza del prodotto di pericolo o avvertenza indica che esiste il pericolo di scossa elettrica che può provocare lesioni personali nel caso di mancata osservanza delle istruzioni.



Questo è il simbolo di allarme di sicurezza. Viene utilizzato per avvertire della possibilità di lesioni personali. Rispettare tutti i messaggi di sicurezza che seguono questo simbolo per evitare possibili lesioni o morte.

▲ PERICOLO

PERICOLO indica una situazione di pericolo che, se non evitata, provoca morte o gravi lesioni.

▲ AVVERTENZA

AVVERTENZA indica una situazione di pericolo che, se non evitata, potrebbe provocare morte o gravi lesioni.

▲ ATTENZIONE

ATTENZIONE indica una situazione di pericolo che, se non evitata, potrebbe provocare lesioni leggere o moderate.

AVVISO

AVVISO si riferisce a pratiche non correlate a lesioni fisiche.

Informazioni di carattere generale e per la sicurezza

CONSERVARE LE PRESENTI ISTRUZIONI

Il presente manuale contiene istruzioni importanti per l'installazione e la manutenzione dell'UPS e delle batterie. Ispezionare il contenuto della confezione alla consegna. Informare il vettore e il rivenditore qualora si riscontrino danni.

- L'UPS è stato progettato esclusivamente per l'uso in ambienti chiusi.
- Non esporre questo UPS alla luce diretta del sole, al contatto con liquidi o a eccessiva polvere o umidità.
- Non utilizzare l'UPS accanto a finestre o porte aperte.
- Verificare che le prese d'aria sull'UPS non siano bloccate. Controllare che vi sia spazio sufficiente per una ventilazione adeguata.

Nota: lasciare uno spazio minimo di 20 cm su tutti i quattro lati dell'UPS.

- I fattori ambientali influiscono sulla durata della batteria. Temperature ambiente elevate, alimentazione di rete di scarsa qualità nonché scariche frequenti riducono la durata della batteria. Seguire le raccomandazioni del produttore della batteria.
- Collegare il cavo dell'UPS direttamente a una presa a muro. Non utilizzare protezioni da sovratensioni o prolunghe.

Sicurezza elettrica

- Quando non è possibile verificare la messa a terra, scollegare l'apparecchiatura dalla presa di alimentazione elettrica prima di installarla o collegarla ad altre apparecchiature. Ricollegare il cavo di alimentazione solamente dopo aver eseguito tutti gli altri collegamenti.
- Il collegamento al circuito di derivazione (rete) deve essere effettuato da un elettricista qualificato.
- Il conduttore di terra protettivo dell'UPS trasporta la corrente di dispersione dalle periferiche di carico (attrezzatura per computer). Come parte del circuito di derivazione che alimenta l'UPS, è necessario installare un filo di terra isolato. Il filo di terra deve essere identico per dimensioni e materiale isolante ai fili dell'alimentazione del circuito di derivazione, sia dotati che privi di massa. Il filo deve essere di colore verde, con o senza striscia gialla.
- Il filo di terra deve essere collegato alla terra dell'apparecchiatura; se alimentato da un sistema di derivazione separato, deve invece essere collegato al trasformatore di alimentazione o al gruppo motore generatore.

Sicurezza delle batterie

⚠ ATTENZIONE

GAS DI IDROGENO SOLFORATO E FUMO ECCESSIVO

- Le batterie devono essere sostituite quando raggiungono la fine della vita utile.
- Le batterie devono essere sostituite quando l'unità indica che è necessario sostituirle.
- Sostituire le batterie con altre nella stessa quantità e dello stesso tipo di quelle installate originariamente nell'unità.

Il mancato rispetto di queste istruzioni potrebbe provocare lesioni e danni moderati o minori all'apparecchiatura.

- Non eliminare le batterie gettandole nelle fiamme, altrimenti, potrebbero esplodere.
- Non aprire o tagliare le batterie. L'elettrolita rilasciato è pericoloso per la pelle e per gli occhi e può essere tossico.
- La manutenzione delle batterie deve essere effettuata o supervisionata da personale esperto in materia e a conoscenza di tutte le necessarie precauzioni.
- Schneider Electric utilizza batterie senza bisogno di manutenzione sigillate agli acidi di piombo. In caso di utilizzo normale, non vi è contatto con i componenti interni delle batterie. Sovraccarico, surriscaldamento o uso improprio delle batterie possono causare una scarica di elettrolito della batteria, in quanto l'elettrolito rilasciato è tossico e può essere pericoloso per la cute e gli occhi.
- **ATTENZIONE:** quando si sostituiscono le batterie, non indossare gioielli quali catene, orologi da polso o anelli. Elevati livelli di energia trasferiti da materiali conduttivi possono provocare gravi ustioni.

Avvertenza sulla radiofrequenza

Questo prodotto è un UPS di categoria C2. In un'area abitata, questo prodotto può causare interferenze radio; in tal caso l'utente dovrà prendere precauzioni aggiuntive.

Descrizione del prodotto

Easy UPS di Schneider Electric è un gruppo di continuità (UPS) a elevate prestazioni. L'UPS protegge le attrezzature elettroniche da blackout, abbassamento di tensione, sottotensione, sovratensione, piccole fluttuazioni e disturbi di grandi dimensioni. L'UPS fornisce anche una batteria di backup che alimenta le attrezzature collegate finché la corrente elettrica torna a livelli normali, oppure finché si scarica la batteria.

Questo Manuale d'uso è disponibile sul CD con la documentazione fornito in dotazione e sul sito Web di Schneider Electric, all'indirizzo www.apc.com.

Contenuto della confezione

Prima di installare il gruppo di continuità, leggere la Guida per la sicurezza.

Il materiale d'imballo è riciclabile; conservarlo per l'eventuale riutilizzo o smaltirlo in modo appropriato.

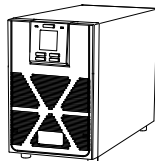

(1)
UPS



(1)
Manuale dell'utente



(1)
Software, CD con la
documentazione per l'utente



(1)
Cavo USB



(1*)
Cavo di alimentazione di rete



(1**)
Cavo di uscita

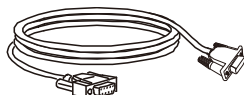

(1)
Cavo RS-232

*: in base alla presa di ingresso locale da selezionare. **: solo per modelli con uscita IEC (10 A).

NOTA: il modello e i numeri di serie sono riportati su una piccola etichetta nel coperchio superiore.

Accessori opzionali

Per accessori opzionali, fare riferimento al sito Web di Schneider Electric all'indirizzo www.apc.com.

Specifiche

Specifiche ambientali

AVVISO



RISCHIO DI DANNI ALLE APPARECCHIATURE PROTETTE

- L'UPS è solo per uso interno.
- La superficie di installazione deve essere solida per sostenere il peso dell'UPS.
- Non utilizzare l'UPS in ambienti eccessivamente polverosi o in condizioni di temperatura o umidità non comprese nei limiti specificati.

Il mancato rispetto di queste istruzioni potrebbe provocare danni all'apparecchiatura.

Temperatura	Durante l'uso	Carico nominale da 0° a 40°C. Da 40° a 50°C con riduzione diretta all'80% della massima capacità di carico.	L'unità è stata progettata esclusivamente per l'uso in ambienti chiusi. Collocarla su una superficie sufficientemente solida da sorreggerne il peso. Non utilizzare l'UPS in ambienti eccessivamente polverosi o in condizioni di temperatura o umidità non comprese nei limiti specificati. Nota: caricare i moduli batteria ogni sei mesi durante l'immagazzinaggio.
	Durante l'immagazzinamento	Da -20° a 50°C	
Altitudine	Durante l'uso	0 - 1.000 m: funzionamento normale 1.000 - 3.000 m: Il carico si riduce a 1% con un incremento di altezza di ogni 100 m > 3.000 m: L'UPS non funziona	
	Durante l'immagazzinamento	0 - 15.000 m	
Umidità		Da 0 a 95% di umidità relativa, senza condensazione	

Caratteristiche fisiche

Modello di UPS	SRVS 1000VA	SRVS 2000VA	SRVS 3000VA
Dimensioni con imballaggio Larghezza x Altezza x Profondità	235 mm (9,25") x 330 mm (12,99") x 365 mm (14,37")	235 mm (9,25") x 355 mm (13,98") x 525 mm (20,67")	325 mm (12,8") x 465 mm (18,31") x 565 mm (22,24")
Dimensioni senza imballaggio Larghezza x Altezza x Profondità	145 mm (5,7") x 223 mm (8,78") x 288 mm (11,34")	145 mm (5,7") x 238 mm (9,37") x 400 mm (15,75")	190 mm (7,5") x 336 mm (13,2") x 425 mm (16,7")
Peso con imballaggio	10,6 kg	18,1 kg	29 kg
Peso senza imballaggio	9,3 kg	16,8 kg	26,8 kg
Indicazioni sul sollevamento	< 18 kg (< 40 lb) 	18 - 32 kg (40 - 70 lb) 	18 - 32 kg (40 - 70 lb) 

Specifiche di ingresso/uscita

Modello di UPS		SRVS 1000VA	SRVS 2000VA	SRVS 3000VA
Ingresso	Tensione	230 V CA nominale		
	Frequenza	40 – 70 Hz		
	Intervallo di tensione di ingresso (carico del 100%)	160 V CA – 280 V CA		
	Intervallo di tensione di ingresso (carico del 50%)	110 V CA – 285 V CA		
	Fattore di potenza in ingresso (carico resistivo del 100%)	≥ 0,99 in Modalità risparmio energetico ≥ 0,93 in modalità Normale		
	Protezione in ingresso	Interruttore automatico di ingresso		
Uscita	Capacità UPS	1000 VA / 800 W	2000 VA / 1600 W	3000 VA / 2400 W
	Tensione nominale di uscita	230 V CA		
	Altre tensioni programmabili	220 V CA, 240 V CA		
	Efficienza a carico nominale	88% max.		
	Regolazione della tensione di uscita	± 1% statico		
	Distorsione di tensione in uscita	<ul style="list-style-type: none"> • 3% max. per carico lineare completo, • 6% max. per carico RCD completo (100% VA, 0,8 PF) • 15% per gli ultimi 60 secondi del tempo di backup (a carico pieno solo per la batteria interna) 		
	Frequenza in batteria	50 Hz ± 0,5% o 60 Hz ± 0,5%		
	Frequenza – Modalità CA	50 Hz ± 3 Hz o 60 Hz ± 3 Hz		
	Fattore di cresta	3:1		
	Forma d'onda	Onda sinusoidale		
	Collegamento in uscita	Fare riferimento alle caratteristiche del pannello posteriore		
Bypass	Bypass interno			

Batteria

Modello di UPS	SRVS 1000VA	SRVS 2000VA	SRVS 3000VA
Configurazione	Batteria interna		
Digitare	Ermetica, senza manutenzione (SMF) 12 V, 9 Ah		
Tensione banco batteria	24 V	48 V	72 V

Display del pannello frontale

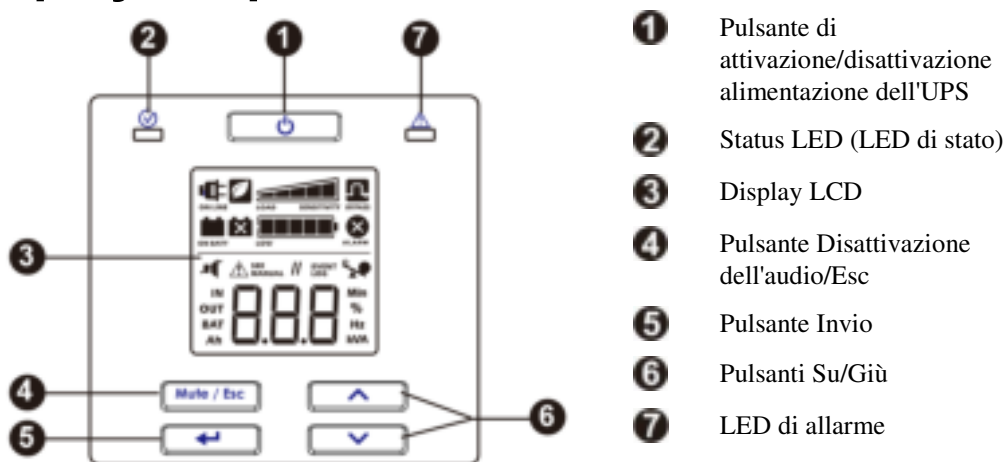

Caratteristiche del pannello posteriore

SRVS 1000VA

Modello	Tipo di uscita e quantità
SRVS1KI	 x 3

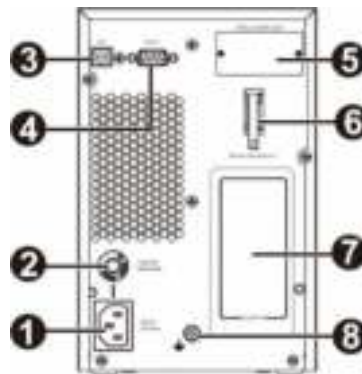

- 1** Ingresso CA
- 2** Interruttore automatico di ingresso
- 3** Porta USB
- 4** RS-232
- 5** Slot per scheda smart
- 6** Sezionatore batteria
- 7** Gruppo di prese (fare riferimento al tipo di uscita e alla quantità nel lato sinistro)
- 8** Vite di messa a terra

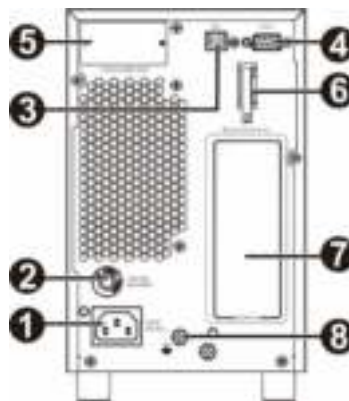

SRVS 2000VA

Modello	Tipo di uscita e quantità
SRVS2KI	 x4



- 1** Ingresso CA
- 2** Interruttore automatico di ingresso
- 3** Porta USB
- 4** RS-232
- 5** Slot per scheda smart
- 6** Sezionatore batteria
- 7** Gruppo di prese (fare riferimento al tipo di uscita e alla quantità nel lato sinistro)
- 8** Vite di messa a terra

SRVS 3000VA

Modello	Tipo di uscita e quantità
SRVS3KI	 x6
	 x1

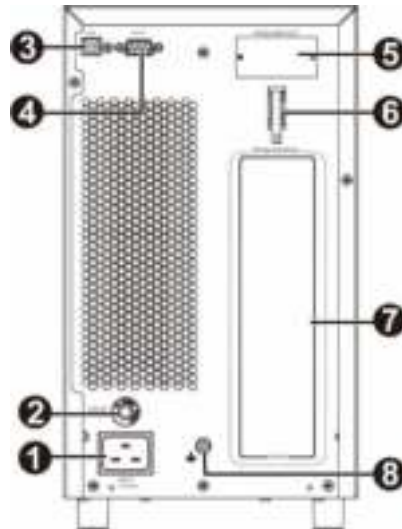

- | | | | |
|----------|-------------------------------------|----------|--|
| 1 | Ingresso CA | 5 | Slot per scheda smart |
| 2 | Interruttore automatico di ingresso | 6 | Sezionatore batteria |
| 3 | Porta USB | 7 | Gruppo di prese (fare riferimento al tipo di uscita e alla quantità nel lato sinistro) |
| 4 | RS-232 | 8 | Vite di messa a terra |

Connettori principali



Il gruppo di continuità consente l'utilizzo di software per la gestione dell'alimentazione e di kit d'interfaccia.
Utilizzare esclusivamente kit interfaccia forniti o approvati da Schneider Electric.

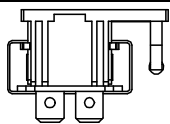

Sezionatore batteria

Il presente UPS è dotato di una batteria interna. Per le batterie senza collegamento quando l'UPS viene fornito dalla fabbrica. Prima di accendere l'UPS, collegare la batteria sollevando la maniglia, quindi spingendola nell'unità.

Impostazioni di avvio

Collegamento della batteria

Collegare la batteria sollevando la maniglia, quindi spingendola nell'unità.

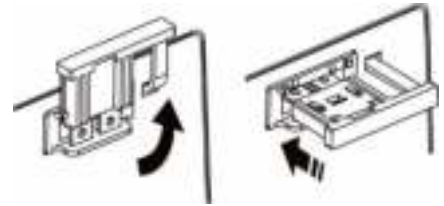

Collegamento della corrente e dell'attrezzatura al gruppo di continuità

⚠ ATTENZIONE

PERICOLO DI SCOSSE ELETTRICHE

- È necessario affidare le operazioni di tipo elettrico ad un elettricista qualificato.
- Scollegare l'alimentazione dall'apparecchiatura prima di eseguire delle operazioni su di essa. Eseguire procedure di blocco/identificazione.
- Non indossare oggetti di bigiotteria quando si lavora con le apparecchiature elettriche.

Il mancato rispetto di queste istruzioni potrebbe provocare lesioni moderate o minori.

1. Collegare le apparecchiature al gruppo di continuità. Evitare di ricorrere a una prolunga.
2. Collegare l'alimentazione di ingresso all'UPS.
3. Accendere l'alimentazione di ingresso. Il pannello del display dell'UPS si illumina quando è disponibile l'alimentazione.



Avvio del gruppo di continuità

Premere il tasto  situato sul pannello frontale dell'UPS.

- La batteria si carica al 90% della capacità di esercizio durante le prime cinque ore di funzionamento normale.
- Durante questo periodo di carica iniziale la batteria **non** funziona al massimo della propria capacità.

Avvio a freddo dell'UPS

Utilizzare la funzione di avvio a freddo per alimentare le attrezzature collegate utilizzando le batterie dell'UPS.

Premere il tasto . Quindi, il pannello del display si illumina. Premere di nuovo il tasto  per fornire alimentazione a batteria alle apparecchiature collegate.

Collegamento e installazione del software di gestione

Easy UPS SRVS è dotato di software di gestione SchneiderUPS per un arresto non sorvegliato del sistema operativo, il monitoraggio dell'UPS, il controllo dell'UPS e la segnalazione dell'energia. Il seguente schema è una rappresentazione di un'installazione tipica del server.

1. Collegare il cavo USB dal retro dell'UPS  al dispositivo protetto, ad esempio un server.

2. Per un server o un altro dispositivo con un sistema operativo, caricare il CD SchneiderUPS e seguire le istruzioni di configurazione su schermo.

3. Una porta seriale integrata  è inoltre disponibile per ulteriori opzioni di comunicazione con un cavo seriale.

4. Tramite slot per scheda smart integrato sono disponibili ulteriori opzioni di comunicazione. Per ulteriori informazioni, fare riferimento al sito Web www.apc.com.

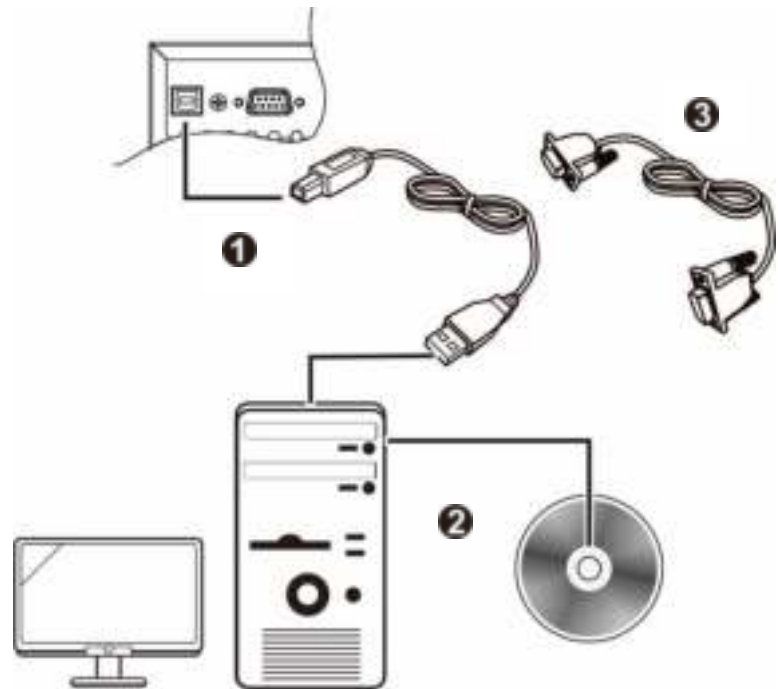







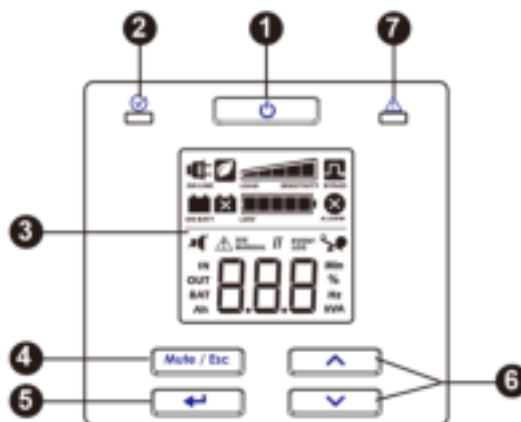

Funzionamento









Utilizzo del display

Questi modelli Easy UPS sono dotati di display LCD intuitivo e configurabile. Questo display integra l'interfaccia del software in quanto trasmettono informazioni simili e possono essere utilizzati per configurare le impostazioni dell'UPS. Il display è costituito dai seguenti tasti e indicatori:



1	Pulsante di attivazione/disattivazione alimentazione dell'UPS 	<ul style="list-style-type: none"> ● Premere questo pulsante per accendere il gruppo di continuità. ● Tenere premuto questo tasto finché non si sente un segnale acustico per spegnere l'UPS. ● Premere questo tasto per ripristinare gli allarmi.
2	LED di stato 	<p>Il LED di stato si accende in verde quando si accende l'alimentazione. Questo LED indica due diversi stati dell'alimentazione in uscita:</p> <ul style="list-style-type: none"> ● Uscita disabilitata: il LED lampeggia. Premere il tasto di attivazione/disattivazione alimentazione per accendere l'alimentazione in uscita. ● Presa accesa: il LED si accende continuamente in verde.
3	Display LCD	Le opzioni dell'interfaccia del display sono visibili su questo schermo LCD. Premere il tasto  o  per attivare lo schermo LCD, se non è illuminato.
4	Pulsante Disattivazione dell'audio/Esc 	<ul style="list-style-type: none"> ● Per riconoscere gli allarmi acustici e per sopprimerli temporaneamente. ● Per uscire da un menu secondario e tornare al menu principale.
5	Pulsante Invio 	Premere questo tasto per accedere al menu o per selezionare una voce/valore del menu durante la navigazione.
6	Pulsanti Su/Giù  	Premere questi due tasti per scorrere tra le opzioni del menu principale e le schermate del display.
7	LED di allarme 	Questo LED di allarme si accende in rosso quando l'UPS rileva un errore e lampeggia in rosso per le notifiche dell'UPS. Vedere "Allarmi e notifiche" a pagina 11 del presente manuale.

Icone del display LCD

 ON LINE	In linea: l'UPS riceve l'alimentazione di rete ed esegue una doppia conversione per erogare corrente alle apparecchiature collegate.
 ON BATT	Alimentazione a batteria: l'UPS sta alimentando le apparecchiature collegate mediante la batteria.
	Sostituzione della batteria: la batteria non è collegata in modo sicuro o è quasi al termine della sua vita utile e deve essere sostituita.
 BYPASS	Bypass: il gruppo di continuità è in modalità di bypass e sta inviando l'alimentazione di rete direttamente alle apparecchiature collegate. Il funzionamento della modalità Bypass è il risultato di un evento interno UPS o una condizione di sovraccarico. In questa modalità non è disponibile l'alimentazione a batteria. Vedere "Allarmi e notifiche" a pagina 11 del presente manuale. Questa icona, in combinazione con Modalità risparmio energetico, indica che l'UPS funziona in Modalità risparmio energetico.
 ALARM	Allarmi di sistema: guasto interno rilevato. Vedere "Allarmi e notifiche" a pagina 11 del presente manuale.
	Sovraccarico: l'apparecchiatura collegata all'UPS sta utilizzando più alimentazione di quanto consentito dal valore nominale.
 LOW	Carica della batteria: il livello di carica della batteria è indicato dal numero di sezioni della barra illuminate. Quando tutte e cinque le barre sono accese, la batteria è completamente carica. Ciascuna barra rappresenta circa il 20% della capacità di carica della batteria.
 LOAD SENSITIVITY	Livello di carico: la percentuale di carico è indicata dal numero di sezioni della barra di carico illuminate. Ciascuna barra rappresenta circa il 20% della capacità di carico massimo.
	Disattivazione dell'audio: una linea accesa che attraversa l'icona indica che l'allarme acustico è disattivato.



Modalità risparmio energetico: un'icona illuminata indica che l'unità funziona in Modalità risparmio energetico. L'apparecchiatura collegata riceve direttamente l'ingresso alimentazione di servizio se la tensione di ingresso e la frequenza rientrano nei limiti configurati.



Allarme o notifica: l'UPS ha rilevato un errore o l'UPS è in modalità di configurazione. Vedere "Allarmi e notifiche" a pagina 11 del presente manuale.

EVENT LOG



Evento: l'icona si illumina quando l'utente visualizza un registro degli eventi.

Allarmi ed errori di sistema

Indicatori di stato

Segnali acustici continui, ogni mezzo secondo	Stato batteria in esaurimento - La batteria è quasi scarica. L'UPS si sta per spegnere.
4 segnali acustici ogni 30 secondi (il primo segnale acustico inizia dopo 4 secondi sulla batteria)	Condizione di sovraccarico - L'apparecchiatura collegata all'UPS sta utilizzando più alimentazione di quanto consentito dal valore nominale.
Segnale acustico sempre acceso	Stato a batteria - L'UPS sta alimentando le apparecchiature collegate mediante la batteria.
Brevi segnali acustici ogni 2,5 secondi	Stato di allarme - L'UPS ha rilevato un errore Vedere "Allarmi e notifiche" nel presente manuale.
Brevi segnali acustici ogni mezzo secondo per 1 minuto, ripetizioni ogni 5 ore.	Batteria disconnessa.
Due brevi segnali acustici ogni 5 secondi	Batteria difettosa (sostituzione)
	Stato di bypass evento - L'UPS ha rilevato un errore. Le apparecchiature collegate ricevono alimentazione di rete in ingresso tramite il relè di bypass.

Allarmi

Codice di visualizzazione	Descrizione	Soluzione
SC	L'UPS ha presentato un cortocircuito sulla presa. L'unità cercherà di ripristinarsi automaticamente da questa condizione.	Verificare la presenza di cortocircuito sulla presa dell'UPS. Rimuovere il cortocircuito e attendere il ripristino automatico o premere il tasto  per avviare l'UPS. Nota: l'alimentazione fornita alle apparecchiature collegate cala quando l'UPS è in questa condizione.
OL	L'UPS presenta una condizione di sovraccarico.	Scollegare le apparecchiature non indispensabili dal gruppo di continuità per eliminare la condizione di sovraccarico.
dCH	L'UPS ha rilevato un errore di tensione CC. L'unità cercherà di ripristinarsi automaticamente da questa condizione.	Se l'UPS non si ripristina automaticamente, contattare Schneider Electric.
Hot	La temperatura dell'unità aumenta oltre i limiti impostati.	Scollegare le apparecchiature non indispensabili dall'UPS per ridurre il carico dell'UPS. Assicurarsi che la temperatura ambiente rientri nei limiti. Assicurarsi che venga mantenuta una distanza adeguata.
CH9	L'UPS ha rilevato un errore del caricatore.	Verificare la presenza di cortocircuito sul terminale della batteria dell'UPS. Premere il tasto  per avviare l'UPS.



Contattare Schneider Electric per tutti gli altri codici di allarme.

Notifiche

Codice di visualizzazione	Descrizione	Soluzione
	Batteria non collegata.	Collegare le apparecchiature all'UPS. Vedere "Avvio" a pagina 8 del presente manuale.

Parametri del display UPS

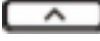
I dati operativi visualizzati nel pannello del display sono forniti nella tabella.











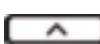

Navigare utilizzando il tasto  o .

Parametro	Unità	Icone dell'indicatore
Tensione di uscita	V CA	OUT, V
Frequenza di uscita	Hz	OUT, Hz
Tensione in ingresso	V CA	IN, V
Frequenza in ingresso	Hz	IN, Hz
Tensione batteria	V CC	BAT, V
Temperatura ambiente	° C	NUMERO, C
Stato di carica della batteria	%	BAT, %
Livello di carica in percentuale (massimo di Watt o VA)	%	OUT, %
Livello di carica in kVA	kVA	OUT, kVA
Totale capacità Ah della batteria collegata	Ah	BAT, Ah
Autonomia restante durante il funzionamento a batteria	minuti	BAT, Min

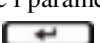
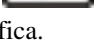
Configurazione

Configurazione dei parametri dell'UPS

Attenersi alle procedure per configurare i parametri dell'UPS.



1. Premere il tasto .
2. Premere il tasto  o  per navigare a "Imposta".
3. Premere il tasto .
4. Navigare tramite i parametri utilizzando il tasto  o .
5. Premere il tasto  per modificare un parametro. Le icone iniziano a lampeggiare per indicare la modifica.
6. Premere il tasto  o  per navigare tra le opzioni disponibili per il parametro selezionato.
7. Premere il tasto  per selezionare l'opzione o il tasto  per ignorare la modifica del parametro attuale. Il lampeggio delle icone si arresta successivamente.
8. Premere il tasto  o  per navigare a tra i parametri.
9. Premere il tasto  per uscire dalla navigazione del menu.















Impostazioni UPS

Configurare le impostazioni dell'UPS tramite l'interfaccia del display. Vedere la sezione "Configurazione dei parametri dell'UPS" per modificare i parametri.

Funzione	Impostazione predefinita	Opzioni selezionabili dall'utente	Descrizione
Tensione di uscita	230 V CA	220, 230, 240 V CA	Consente all'utente di selezionare la tensione di uscita mentre l'UPS funziona online.
Allarme acustico	Attiva	Abilita, Disabilita	L'UPS disattiva l'audio degli allarmi acustici se impostato su disabilita o quando si preme il tasto MUTE del pannello del display.
Modalità risparmio energetico/modalità di efficienza elevata	Disattivato	Attivazione/disattivazione	Quando si abilita questa modalità, l'apparecchiatura collegata riceve l'alimentazione di rete in ingresso attraverso il relè di bypass finché la tensione di ingresso non rientra nella gamma di $\pm 5\%$ della tensione di uscita configurata e di ± 3 Hz della frequenza di uscita configurata. L'inverter viene spento durante questa modalità. Se l'alimentazione di rete in ingresso si spegne, l'inverter è acceso. Il carico viene trasferito in modalità online o in modalità batteria. L'alimentazione all'apparecchiatura collegata può essere interrotto fino a 10 millisecondi.
Impostazione capacità minima della batteria per il riavvio	0%	0%, 15%, 50%, 90%,	La presa dell'UPS non si accende finché la batteria non viene caricata a un livello tale da fornire l'autonomia configurata da questa impostazione. Se configurato su 0%, la presa dell'UPS si accende subito dopo che si ripristina l'alimentazione di rete.
Impostazione dell'indicazione di stato batteria in esaurimento	2 min	2 min, 5 min, 7 min, 10 min	L'UPS emette un allarme acustico quando il tempo di esecuzione effettivo raggiunge il limite impostato dall'utente finale. L'allarme acustico viene emesso solo quando l'UPS funziona in modalità batteria.



Navigazione avanzata del display



Nel menu principale sono disponibili cinque opzioni e nel display dell'UPS due opzioni del sottomenu. Premere il tasto  dalla schermata iniziale per accedere a queste opzioni del menu. Utilizzare il tasto  o  per spostarsi tra le opzioni del menu.

Opzione del menu	Descrizione
SET	<p>Configurazione dell'UPS</p> <p>Utilizzare questa opzione di menu per configurare i parametri dell'UPS. Premere il tasto  per vedere le opzioni di configurazione. Vedere "Configurazione dei parametri dell'UPS" a pagina 13 per i dettagli. Premere il tasto  per tornare alla schermata iniziale.</p>
LOG	<p>Mostra registro eventi</p> <p>Utilizzare questa opzione di menu per vedere il registro degli eventi dell'UPS. L'UPS registra gli ultimi 10 eventi e visualizza i codici in questo registro.</p> <p>Premere il tasto  per vedere il registro. Utilizzare il tasto  o  per vedere gli eventi registrati. Il tasto  consente di navigare verso gli eventi meno recenti e il tasto  verso i nuovi eventi.</p> <p>Ogni voce di registro dispone di un codice evento numerico e testuale. Alla fine del registro, viene visualizzata la parola "Fine". Premere il tasto  per tornare alla schermata iniziale.</p>
UPS	<p>Mostra informazioni UPS</p> <p>Utilizzare questa opzione di menu per vedere le informazioni dell'UPS. Premere il tasto  per visualizzare il valore nominale dell'UPS.</p> <p>Premere il tasto  per vedere la versione firmware dell'UPS. Premere il tasto  per tornare alla schermata iniziale.</p>
bYP	<p>Comando utente per bypass</p> <p>Utilizzare questa opzione di menu per commutare l'UPS in modalità bypass o portare l'UPS in modalità online dalla modalità bypass.</p> <p>Premere il tasto :</p> <p>Put utilizzare per portare l'UPS in modalità bypass.</p> <p>Nota: l'alimentazione all'apparecchiatura collegata si riduce se la tensione di rete non rientra nei limiti di soglia.</p> <p>Out: ripristinare l'UPS dalla modalità bypass e riportare l'alimentazione all'apparecchiatura collegata.</p>
tSt	<p>Esegui test automatico batterie</p> <p>Utilizzare questa opzione di menu per effettuare un test automatico e determinare lo stato delle batterie. Premere il tasto  per avviare il test.</p> <p>Se il comando di test viene accettato, l'UPS avvia un test automatico e inizia il conto alla rovescia sul display.</p> <p>I messaggi del display vengono visualizzati alla fine del test.</p> <p>rFd Test rifiutato. La presa è spenta o la batteria non viene caricata.</p> <p>Fl d Test non superato</p> <p>PRs Test superato</p> <p>Abt Test interrotto per motivi interni</p> <p>Premere il tasto  per tornare alla schermata iniziale.</p>

Risoluzione dei problemi

Ricorrere alla tabella seguente per risolvere piccoli problemi durante l'installazione e il funzionamento. Visitare il sito web Schneider Electric www.apc.com per assistenza nel caso di problemi più complessi.

Problema e/o possibile causa	Soluzione
L'UPS non si accende quando l'alimentazione di rete in ingresso non è disponibile o non viene rilevata alcuna presa	
L'UPS non si accende.	Premere il pulsante di  per accendere l'UPS.
Il gruppo di continuità non è collegato alla rete elettrica.	Verificare che il cavo di alimentazione dal gruppo di continuità alla presa di rete sia collegato saldamente ad entrambi i capi. Vedere "Avvio" a pagina 8 del presente manuale.
Si è attivato il termointerruttore di ingresso sull'UPS.	Premere il tasto di ripristino del termointerruttore nel pannello posteriore.
L'UPS funziona a batteria mentre è collegato alla rete elettrica in ingresso	
La tensione di ingresso o la frequenza sono elevate, basse o distorte.	Collegare l'UPS a un'altra presa su un altro circuito. Effettuare un test dell'alimentazione di rete in ingresso per verificare che l'unità riceva alimentazione in ingresso. Se il display è acceso, navigare e controllare la tensione di ingresso e la frequenza.
L'UPS, se non è collegato alla batteria, non fornisce alimentazione all'apparecchiatura collegata	
L'UPS non si accende.	Se l'UPS si è spento (il display non è acceso), seguire la procedura di "Avvio a freddo dell'UPS" a pagina 8.
Batteria non collegata.	Collegare le apparecchiature all'UPS. Vedere "Avvio" a pagina 8 del presente manuale.
Batteria scarica. L'UPS potrebbe aver scaricato la batteria a causa dell'interruzione dell'alimentazione e aver spento l'uscita a seguito di batteria scarica.	Attendere che venga ripristinata l'alimentazione e che la batteria venga caricata. Per accendere l'alimentazione dopo il ripristino premere il tasto  .
L'UPS emette un segnale acustico a intervalli prolungati	
L'UPS funziona normalmente a batteria.	L'UPS ha rilevato un errore. Vedere "Allarmi e notifiche" a pagina 11 del presente manuale.
Il LED di allarme si accende. L'UPS visualizza un messaggio di allarme ed emette un suono costante.	
L'UPS ha rilevato un errore.	Vedere "Allarmi e notifiche" a pagina 11 del presente manuale.
Nessun segnale acustico dall'UPS anche con il LED di allarme acceso.	
Allarme acustico disabilitato.	Modificare la configurazione dell'UPS per abilitare gli allarmi acustici.
Il gruppo di continuità non fornisce il tempo di backup previsto.	
La batteria UPS si scarica a causa di un'interruzione di corrente recente.	Dopo interruzioni prolungate dell'alimentazione è sempre necessario ricaricare le batterie. Se vengono utilizzate senza una corretta carica o in presenza di temperature elevate, le batterie si usurano con maggiore velocità.
La durata utile della batteria è quasi esaurita.	Se la batteria è vicina alla fine della sua durata utile, considerare di sostituire la batteria anche se l'indicatore della batteria non si è acceso. Vedere "Avvio" a pagina 8 del presente manuale.

Problema e/o possibile causa	Soluzione
L'UPS non si spegne	
Tasto POWER OFF non premuto correttamente	Tenere premuto il tasto  finché non si sente il segnale acustico per spegnere l'UPS.
È disponibile l'alimentazione di rete in ingresso.	Non è possibile spegnere l'alimentatore logica dell'UPS se è disponibile l'alimentazione di rete in ingresso. Per spegnere l'UPS, spegnere l'alimentazione di rete in ingresso e premere il tasto  . Rilasciare quando si sente un segnale acustico.
UPS in modalità Bypass e LED non acceso in rosso.	
UPS in Modalità risparmio energetico.	Disabilitare la Modalità risparmio energetico, se non desiderata.
UPS configurato per rimanere in modalità bypass.	Cambiare la configurazione per uscire dalla modalità bypass.
UPS in modalità bypass anche se si cancella l'allarme di surriscaldamento.	Ridurre il carico collegato a <90% per portare l'UPS in modalità online.
L'UPS ha presentato una condizione di sovraccarico ed è passato in modalità bypass.	<p>Le apparecchiature collegate superano il "carico massimo" indicato nella sezione relativa ai dati tecnici del sito Web di Schneider Electric all'indirizzo www.apc.com.</p> <p>Gli allarmi rimangono attivi finché non si corregge la condizione di sovraccarico. Scollegare le apparecchiature non indispensabili dal gruppo di continuità per eliminare la condizione di sovraccarico.</p> <p>L'UPS continua ad erogare l'alimentazione fino a che rimane in modalità bypass e l'interruttore automatico non salta.</p> <p>L'UPS non fornirà alimentazione dalle batterie in caso di interruzione della tensione di rete.</p>
L'UPS ha rilevato un errore ed è passato in modalità bypass.	Vedere "Allarmi e notifiche" a pagina 11 del presente manuale.

Trasporto

1. Arrestare e scollegare tutte le apparecchiature collegate.
2. Scollegare l'unità dall'alimentazione di rete.
3. Scollegare tutte le batterie interne ed esterne (se pertinente).
4. Attenersi alle istruzioni per la spedizione fornite nella sezione *Assistenza* del presente manuale.

Assistenza

Se l'unità necessita di assistenza, non restituirla al rivenditore. Attenersi alla procedura riportata di seguito:

1. Per eliminare i problemi più comuni, fare riferimento alla sezione *Risoluzione dei problemi* del manuale.
2. Se il problema persiste, rivolgersi all'assistenza clienti Schneider Electric tramite il sito Web Schneider Electric all'indirizzo **www.apc.com**.
 - a › Prendere nota del numero del modello, del numero di serie e della data di acquisto. Il modello e i numeri di serie sono riportati sul pannello posteriore dell'unità e su alcuni modelli possono essere visualizzati nel display LCD.
 - b › Contattare il servizio di assistenza clienti. Un tecnico tenterà di risolvere il problema per telefono. In caso contrario, il tecnico fornirà un numero di autorizzazione per la restituzione dei materiali (numero RMA).
 - c › Se l'unità è in garanzia, le riparazioni saranno gratuite.
 - d › Le procedure per l'assistenza o la restituzione dei prodotti possono variare da paese a paese. Per le istruzioni specifiche per ogni Paese, fare riferimento al sito Web di Schneider Electric all'indirizzo **www.apc.com**.
3. Imballare l'unità in maniera adeguata in modo da evitare danni durante il trasporto. Non utilizzare mai fiocchi di polistirolo come materiale d'imballaggio.
I danni subiti durante il trasporto non sono coperti dalla garanzia.
Nota: Prima della consegna, scollegare sempre i moduli batteria dell'UPS o del pacco batteria esterno. Le batterie interne scollegate possono rimanere nell'UPS o nel pacco batteria esterno.
4. Scrivere il numero RMA fornito dall'assistenza clienti all'esterno della confezione.
5. Spedire l'unità mediante pacco assicurato prepagato all'indirizzo fornito dall'assistenza clienti.

Informativa di garanzia di fabbricazione limitata

Schneider Electric IT Corporation (SEIT) garantisce che i propri prodotti sono esenti da difetti nei materiali e nella lavorazione per un periodo di due (2) anni a partire dalla data di acquisto. Gli obblighi di SEIT ai sensi della garanzia si limitano alla riparazione o alla sostituzione, a propria insindacabile discrezione, di eventuali prodotti difettosi. La riparazione o sostituzione di un prodotto difettoso o di una sua parte non estende il periodo di garanzia originale.

La presente garanzia ha validità soltanto per l'acquirente originale che deve aver registrato correttamente il prodotto entro 10 giorni dalla data d'acquisto. È possibile registrare online i Prodotti sul sito Web.warranty.apc.com.

In base alla presente garanzia SEIT non potrà essere ritenuta responsabile se alla verifica e all'esame del prodotto verrà rilevato che il supposto difetto del prodotto non esiste o è stato causato da uso, negligenza, installazione, verifica, funzionamento o utilizzo non corretti da parte dell'utente finale o di terzi, o contrari a raccomandazioni e specifiche fornite da SEIT. SEIT declina inoltre ogni responsabilità nel caso di difetti derivanti da: 1) tentativi di riparazione o modifica al prodotto non autorizzati, 2) tensione o collegamenti elettrici inadeguati o errati, 3) condizioni operative sul posto non appropriate, 4) calamità naturali, 5) esposizione ad agenti atmosferici o 6) furto. Ai sensi della presente garanzia, inoltre, SEIT declina ogni responsabilità per qualsiasi prodotto in ogni caso nel quale il numero di serie sia stato alterato, rovinato o rimosso.

AD ECCEZIONE DI QUANTO RIPORTATO IN PRECEDENZA, NON ESISTONO GARANZIE, IMPLICITE O ESPLICITE, RELATIVE AL PRODOTTO VENDUTO, REVISIONATO O ALLESTITO AI SENSI DEL PRESENTE CONTRATTO.

SEIT NON RICONOSCE ALCUNA GARANZIA IMPLICITA DI COMMERCIALIZZABILITÀ, SODDISFAZIONE O IDONEITÀ PER UNO SCOPO SPECIFICO.

LE GARANZIE ESPRESSE DI SEIT NON VERRANNO AUMENTATE, DIMINuite O INTACCATE E NESSUN OBBLIGO O RESPONSABILITÀ SCATURIRÀ DALLA PRESTAZIONE DI ASSISTENZA TECNICA DA PARTE DI SEIT IN RELAZIONE AI PRODOTTI.

LE SUDETTE GARANZIE E TUTELE SONO ESCLUSIVE E SOSTITUISCONO TUTTE LE ALTRE GARANZIE E TUTELE. LE GARANZIE SUINDICATE COSTITUISCONO L'UNICA RESPONSABILITÀ DI SEIT E IL RIMEDIO ESCLUSIVO DELL'ACQUIRENTE PER QUALUNQUE VIOLAZIONE DI TALI GARANZIE. LE GARANZIE DI SEIT VALGONO ESCLUSIVAMENTE PER L'ACQUIRENTE ORIGINALE E NON SI INTENDONO ESTENDIBILI A TERZI.

IN NESSUNA CIRCOSTANZA SEIT O SUOI FUNZIONARI, DIRIGENTI, AFFILIATI O DIPENDENTI SARANNO RITENUTI RESPONSABILI PER QUALSIASI DANNO DI NATURA INDIRECTA, SPECIALE, CONSEGUENZIALE O PUNITIVA RISULTANTE DALL'USO, ASSISTENZA O INSTALLAZIONE DEI PRODOTTI, SIA CHE TALI DANNI ABBIANO ORIGINE DA ATTO LECITO O ILLECITO, INDIPENDENTEMENTE DA NEGLIGENZA O RESPONSABILITÀ, SIA CHE SEIT SIA STATA AVVISATA IN ANTICIPO DELLA POSSIBILITÀ DI TALI DANNI. NELLA FATTISPECIE, SEIT DECLINA OGNI RESPONSABILITÀ PER EVENTUALI COSTI, QUALI MANCATI UTILI O RICAVI, DIRETTI O INDIRETTI, PERDITA DI APPARECCHIATURE, MANCATO UTILIZZO DELLE APPARECCHIATURE, PERDITA DI SOFTWARE E DI DATI, SPESE DI SOSTITUZIONE, RICHIESTE DI RISARCIMENTO DA PARTE DI TERZI O ALTRO.

NESSUNA CONDIZIONE DELLA PRESENTE GARANZIA LIMITATA SOLLEVA O RIDUCE LA RESPONSABILITÀ DI SEIT PER LESIONI GRAVI O MORTALI DERIVANTI DA UNA PROPRIA NEGLIGENZA O INTENZIONALE CATTIVA INTERPRETAZIONE O DA CONDIZIONI CHE NON POSSONO ESSERE ESCLUSE O LIMITATE DALLE LEGGI APPLICABILI.

Per ottenere assistenza ai sensi della garanzia, è necessario richiedere un numero di autorizzazione per la restituzione dei materiali (RMA) all'assistenza clienti. Per problemi relativi a richieste di indennizzo è possibile rivolgersi alla rete mondiale di assistenza clienti SEIT, accedendo al sito web di Schneider Electric: www.apc.com. Selezionare il proprio paese dall'apposito menu a tendina. Per ottenere informazioni sull'assistenza clienti per la propria zona, accedere alla scheda Assistenza nella parte superiore della pagina Web. I prodotti devono essere restituiti con spese di trasporto prepagate e accompagnati da una breve descrizione del problema riscontrato e dalla prova della data e del luogo di acquisto.

Assistenza clienti internazionale di Schneider Electric

L'assistenza clienti per questo e altri prodotti Schneider Electric può essere richiesta gratuitamente tramite una delle modalità descritte di seguito:

- Visitare il sito Web di Schneider Electric per accedere ai documenti nell'Schneider Electric Knowledge Base e richiedere assistenza.
 - **www.apc.com** (sede principale della società)
Collegarsi alle pagine Web Schneider Electric dei paesi specifici per informazioni sull'assistenza ai clienti.
 - **www.apc.com/support/**
Supporto generale tramite ricerca nell'Schneider Electric Knowledge Base e utilizzando la funzione di supporto online.
- Contattare un Centro assistenza clienti Schneider Electric via telefono o e-mail.
 - Centri locali e nazionali: visitare il sito **www.apc.com/support/contact** per informazioni.

Per informazioni sull'assistenza clienti locale, contattare il rappresentante Schneider Electric o altri distributori presso cui si è acquistato il prodotto Schneider Electric.